

STATE OF ALABAMA)	FRANKLIN COUNTY COMMISSION
)	REGULAR MEETING
FRANKLIN COUNTY)	September 18, 2023 8:30 AM

PRESENT: Honorable Barry Moore, presiding as Judge of Probate and Chairman, and Messrs., Jason Miller, Joseph Baldwin, Chris Wallace, and David Hester as Members.

ALSO PRESENT: Solid Waste Manager Gene Ward, Mark Latham of the Franklin County Sheriff's Office, County Engineer Jason Baggett, Assistant County Engineer Caleb Sherill, County Administrator Leah Mansell, Chase Sparks, Sheila Underwood, Cassie Medley of the Franklin County Chamber of Commerce, Randy Shultz, Lauren Schultz, Scott Mugno, and John Pilati of the *Franklin Free Press*.

CALL TO ORDER

Chairman Barry Moore called the meeting to order.

INVOCATION

The meeting was opened in prayer by Member David Hester.

PLEDGE OF ALLEGIANCE

The Pledge of Allegiance was led by Member Joseph Baldwin.

ROLL CALL

Chairman Barry Moore stated that all Members are present.

PUBLIC COMMENTS

Chairman Moore stated that he had a letter from Administrator Leah Mansell requesting to advertise for the Accountant/Payable Clerk in Commission Office. He stated that item number 1D be added to the agenda regarding the advertisement for Accountant/Payable Clerk in Commission Office.

Chairman Moore stated that he had a letter from Sheriff Shannon Oliver requesting to promote Bretta Wigginton to Lieutenant. He stated that item number 3G be added to the agenda regarding the promotion of Bretta Wigginton to Lieutenant.

Chairman Moore stated that he had a letter from Solid Waste Manager Gene Ward requesting to terminate a HEO and advertise for the position. He stated that item number 4C be added to the agenda regarding the termination of an HEO and 4D be added to the agenda regarding advertising for a HEO in the Solid Waste Department.

County Engineer Jason Baggett stated that he would like to declare a vacancy in the Highway Department due to the death of employee Micky Montgomery. Chairman Moore stated that item number 2B be added to the agenda regarding a vacancy at the Highway Department.

Franklin County Chamber of Commerce Director Cassie Medley addressed the Commission regarding the contract between the Commission and the Chamber of Commerce for FY2024. She stated that the contract has remained the same since 2009 but this year's contract will increase 20% with a 10% increase the next two years. She added that with the price increase comes 3 increases in services. These include utilizing social media to promote Franklin County events, designing and making available to purchase souvenir postcards to promote Franklin County and the Chamber having a direct link from the Chamber's website to Franklin County's website. The Commissioners thanked Cassie for the work she and the Chamber do for Franklin County. Commissioner Miller asked Cassie to give an update on the Pumpkin Palooza coming up that the Chamber is sponsoring. Cassie said that the Pumpkin Palooza Scarecrow Trail will be Saturday, October 7 at City Lake Park from 10 AM to 4 PM. She added that there will be opportunities to sponsor scarecrows and photoboosts.

Randy Schultz of the Franklin County Water Board addressed the Commission concerning issues over the weekend regarding 2 water pumps that stopped working. He said the emergency plan went into effect and there were issues but they are working those out. He added that the pumps are very outdated and it will take 6 months to replace them. He thanked EMA for their help with the issue.

APPROVAL OF AGENDA

It is on motion of Mr. Jason Miller, second by Mr. Chris Wallace, unanimously ordered, adjudged and decreed by the Board to add item number 1D to the agenda concerning advertising for the Accountant/Payable Clerk in the Commission Office.

It is on motion of Mr. David Hester, second by Mr. Joseph Baldwin, unanimously ordered, adjudged and decreed by the Board to add item number 2B to the agenda concerning declaring a vacancy in the Highway Department.

It is on motion of Mr. David Hester, second by Mr. Jason Miller, unanimously ordered, adjudged and decreed by the Board to add item number 3G to the agenda concerning the promotion of Bretta Wigginton to Lieutenant.

It is on motion of Mr. Joseph Baldwin, second by Mr. Jason Miller, unanimously ordered, adjudged and decreed by the Board to add item number 4C to the agenda concerning the

termination of Solid Waste Heavy Equipment Operator Lee Bryant, effective September 13, 2023.

It is on motion of Mr. Joseph Baldwin, second by Mr. David Hester, unanimously ordered, adjudged and decreed by the Board to add item number 4D to the agenda concerning advertising for the Heavy Equipment Operator position in the Solid Waste Department.

It is on motion of Mr. David Hester, second by Mr. Jason Miller, unanimously ordered, adjudged and decreed by the Board to approve the overall agenda as presented to include additions.

APPROVAL OF MINUTES

It is on motion of Mr. David Hester, second by Mr. Jason Miller, unanimously ordered, adjudged and decreed by the Board to approve the August 21, 2023, Regular Meeting Minutes.

APPROVAL OF BILLS

It is on motion of Mr. Chris Wallace, second by Mr. David Hester unanimously ordered, adjudged and decreed by the Board to approve the August bills for payment.

NEW BUSINESS

COMMISSION

JANITORIAL SUPPLY BIDS FY23-24

It is on motion of Mr. Chris Wallace, second by Mr. Jason Miller unanimously ordered, adjudged and decreed by the Board to approve the lowest responsible bid on the janitorial supplies for FY23-24.

Bid information as follows:

Franklin County Commission
FY2023 - 2024 Janitorial Supply Bid Results

American Paper and Twine

One Source Office Supplies

Description	Item #	QTY	U/M	Price / Unit	Total Price	Item #	QTY	U/M	Price / Unit	Total Price
Towel & Tissue										
880N Preserve Hardwood Roll Towel Natural 800' 2" Core	460032		CS	\$ 29.37		J5600	6	R/CS	\$ 4.45	\$ 26.70
47410 Envision White 2 Ply Facial Tissue Flat Box	324400		CS	\$ 39.00		SOL11513	30	R/CS	\$ 0.90	\$ 27.00
524210 Netchoice Kitchen Roll Towel 80 2Ply Sheets/Roll	470071		CS	\$ 35.00		T7100	30	R/CS	\$ 0.98	\$ 29.40
290088 Tork Universal Hardwood Roll Towel Natural 1 Ply 700'	044500		CS	\$ 45.00		290088	6	R/CS	\$ 9.00	\$ 54.00
12024402 Tork Advanced Mini Jumbo Roll Toilet Tissue 2 Ply	046025		CS	\$ 42.00		12024402	12	R/CS	\$ 4.32	\$ 51.84
B50096 Toilet Tissue 2 Ply 500 SH/RL	450029		CS	\$ 45.08		J4000	96	R/CS	\$ 0.44	\$ 42.24
Ernets										
24 x 32 White .50 Mil Low D Liner 12-16 Gal on Roll 20/25	380100		CS	\$ 34.00		MT331XW	10 50	R/CS	\$ 2.65	\$ 26.50
33 X 40 Natural 16 Mic High D Liner 33 Gal on Roll 10/25	380138		CS	\$ 27.98		MR33403MC	10 25	R/CS	\$ 2.55	\$ 25.50
38 x 58 Black 1.2 Mil Low D Liner 60 Gal on Roll 10/10	380080		CS	\$ 24.69		EC385812K	10 10	R/CS	\$ 2.39	\$ 23.90
33 X 39 Black .5 Mil Low D Liner 33 Gallon	386325		CS	\$ 26.00		B74020XK	10 25	R/CS	\$ 2.35	\$ 23.50
40 X 46 White .75 Mil Low D Liner 40-45 Gallon	386367		CS	\$ 24.00		MT481XW	10 10	R/CS	\$ 1.83	\$ 18.30
Soap and Sanitizer										
AmeriClean Hand Sanitizer 32 oz Pump Bottle Gel 70% Alcohol	750040		EA	\$ 4.06		ZPE355825	1	GAL	\$ 23.05	\$ 23.05
2217 GOJO Deluxe Lotion Hand Soap NXT Liquid 2000 ML	046931		CS	\$ 69.05		GOJ221704	4	B/CS	\$ 16.90	\$ 67.60
Soap E1911 LTX Hand Foam 1200M Pomeberry -- Light Blue EXCELON	024555		CS	\$ 52.90						
Purell LTX Green Certified Foam Hand Sanitizer 1200 ML	753737		CS	\$ 80.95						
Janitorial & Restroom Supplies										
32 OZ Cotton Deck Mop With Handle	047887		EA	\$ 9.75		BWK132C	1	EA	\$ 9.95	\$ 9.95
25# White Knit Rags	023160		CS	\$ 49.50		HO553725	1	CS	\$ 54.57	\$ 54.57
7420 Large Angle Broom	170008		EA	\$ 6.15		CWZ24420010	1	EA	\$ 4.94	\$ 4.94
26" - 42" Polywool Duster With Plastic Handle	170003		EA	\$ 7.09						
Pink Luster Dishwashing Detergent 32 OZ	049583		CS	\$ 26.85		CPC144678	9	B/CS	\$ 3.13	\$ 28.17
Disinfecting Wipes, 75 Wipes, 6/CT, Lemon Scent	760008		CT	\$ 6.49		RAC77182	6	C/CS	\$ 5.92	\$ 35.52
Lysol Disinfecting Spray, 12/CS	046927		EA	\$ 8.65		RAC74828	12	C/CS	\$ 7.10	\$ 85.20
Wetlet System Refill Cloths, 11.3" x 5.4", White, 24/Box	1084461		BX	\$ 20.75		PGC08443	24	P/CS	\$ 0.75	\$ 18.00
Lysol Disinfecting Spray Foam, 12/CS	762650		EA	\$ 5.88		RAC02775	12	C/CS	\$ 3.22	\$ 38.64
Clothesline Fresh Laundry Detergent	763724		CS	\$ 78.24						
RM Toilet Bowl Brush 14.5" Plastic Handle White	168422		EA	\$ 2.08						

OFFICE SUPPLY BIDS FY23-24

It is on motion of Mr. Joseph Baldwin, second by Mr. Chris Wallace unanimously ordered, adjudged and decreed by the Board to approve the lowest responsible bid on the office supplies for FY23-24.

Bid information as follows:

FY2023-2024
October 1, 2023 – September 30, 2024

Office Supply Bids

VENDOR'S NAME: One Source

VENDORS'S ADDRESS: 113 Main St East
Hartselle, Al 35640

VENDOR'S TELEPHONE NUMBER: 205-799-6814

VENDOR'S FAX NUMBER: _____

VENDOR'S EMAIL ADDRESS: Scott@onesourceop.com

POINT OF CONTACT FOR VENDOR: Scott Harrison

***IF THIS SHEET IS NOT SIGNED, NOTARIZED AND INCLUDED
WITH BID PRICING, BID IS VOID****

Scott Harrison

Authorized Vendor Representative

Scott Harrison

Typed or Printed Name

Sworn to and subscribed before me this:

The 31 day of August, 2023.

Brandi Ann Whitlow
Notary Public

My Commission Expires: 11-17-24

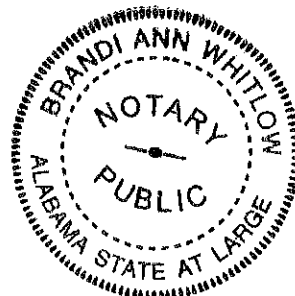



113 Main St East | Hartselle, Alabama 35640 | P(205) 799-6814 | scott@onesourceop.com

The attached paperwork showing the EPIC Business Essentials contract through OMNIA Partners is One Source's bid for the Office Supplies. The contract number R190301 is already an approved contract by the State of Alabama for bid purposes.

Prices are already loaded into Franklin County Commission account on the One Source website for viewing and ordering.

There are over 12,000 items at bid level approved pricing and all other items are at a substantial discounted rate as well.

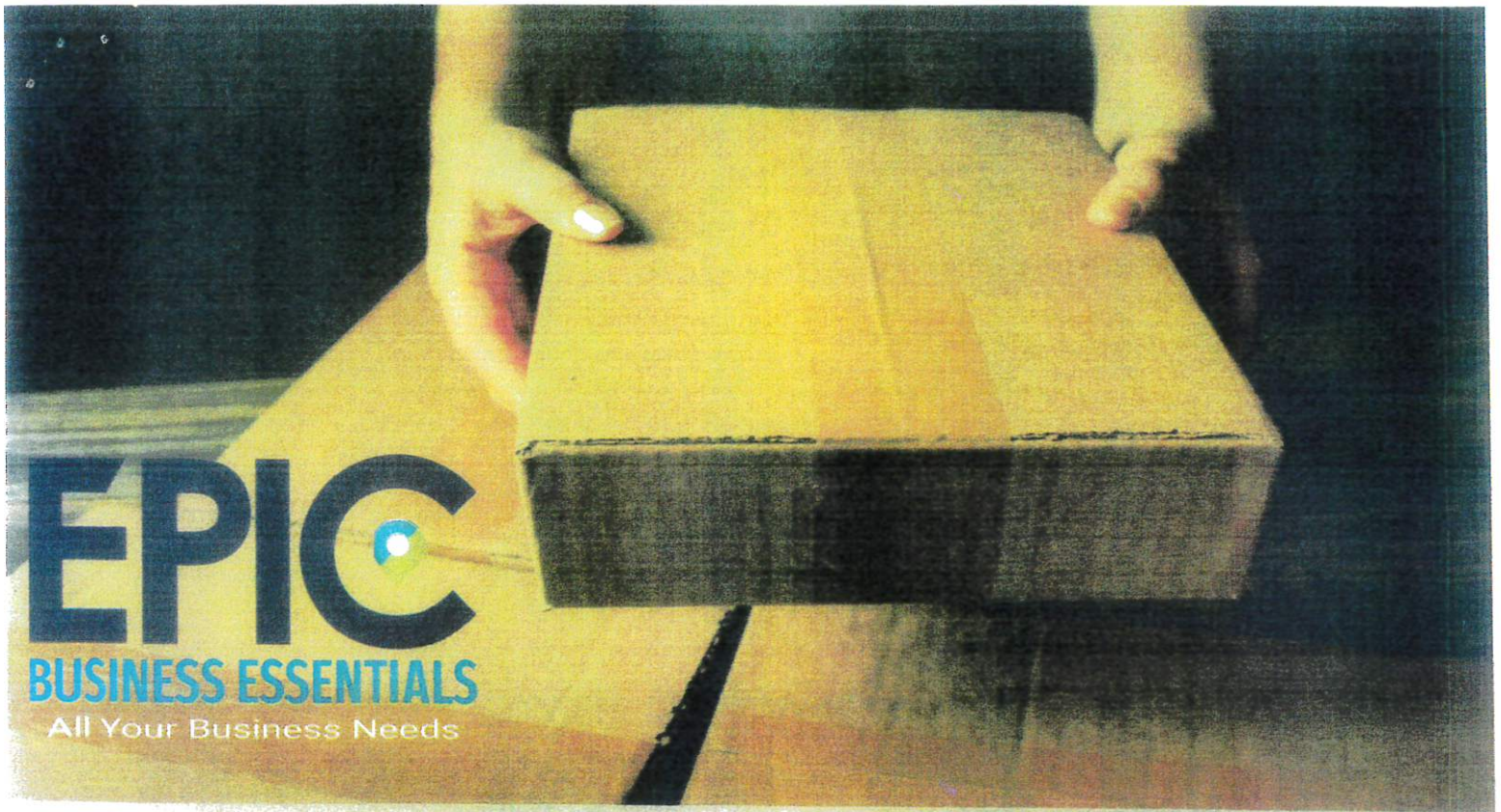

EPIC
BUSINESS ESSENTIALS
All Your Business Needs

Buy Smart, Buy Local

Contract Number
R190301

Contract Valid
Award through June, 2024
Renewals through 2029

Core List Pricing
12,000 items

Tailored Hot List Pricing
500 items

Free Next-Day Delivery
No Minimums

Product Categories
Office Supplies
Office Furniture
Managed Print Services
Energy Procurement
LED Lighting
Energy Efficiency Products
Coffee and Breakroom Services
Office Equipment and Technology
Promotional and Advertising Products
Copy and Print Services
Document Management
Janitorial and Cleaning Supplies
School Supplies

- Pricing at or below the big-box retailers
- Thousands of local dealers with national reach
- The customer service you deserve
from friends and neighbors
- MBE/WBE/DBE certified businesses
- Local spend stays local

Whatever your volume, number of locations, geographic reach or procurement guidelines, EPIC Business Essentials empowers local, independent office supply dealers to fulfill all your business needs. Our network of thousands of local dealers lets you choose the relationships you trust in your own community.

OMNIA Partners, Public Sector is the nation's largest and most experienced cooperative purchasing organization dedicated to public sector procurement. Learn more at omniapartners.com/publicsector

Find Your Local Solution

sales@epicbusinessessentials.com

(800) 231-9848

www.epicbusinessessentials.com

OMNIA
PARTNERS

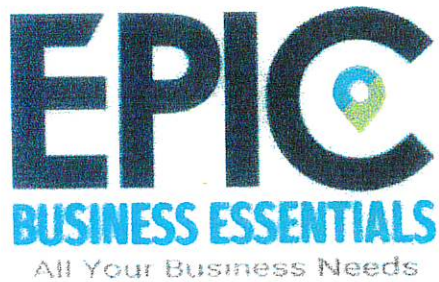

To Whom it May Concern:

Thank you for your interest in the EPIC Business Essentials OMNIA Partners Office Supply contract. This letter is certifying that One Source Office Products located in Northport, AL, acts as an OMNIA Partners approved servicing dealer per the EPIC Business Essentials contract, and as such your office supply needs may be serviced through the OMNIA Partners office supply contract via One Source Office Products. They have the ability to contract directly with public sector agencies utilizing their own website with the loaded OMNIA Partners cooperative national contract. The pricing you will find upon your log in will be OMNIA Partners certified pricing that is supplied and audited on a regular basis by the contract holder EPIC Business Essentials.

Please let me know if I can help in any way, or answer any questions pertaining to your account or the partnership between EPIC Business Essentials and One Source Office Products.

Sincerely,

Scott Zintz

Managing Director

EPIC Business Essentials

5600 N River Rd Ste 700

Rosemont, IL 60018

P - (847) 261-0044

szintz@epicbusinessessentials.com

FY2023-2024
October 1, 2023 – September 30, 2024

Office Supply Bids

VENDOR'S NAME: Printers and Stationers, Inc.

VENDOR'S ADDRESS: 113 N. Court St

Florence, AL 35630

VENDOR'S TELEPHONE NUMBER: (256)-764-8061

VENDOR'S FAX NUMBER: (256)-764-5024

VENDOR'S EMAIL ADDRESS: dillon@printersandstationers.com

POINT OF CONTACT FOR VENDOR: Dillon Putnam

***IF THIS SHEET IS NOT SIGNED, NOTARIZED AND INCLUDED
WITH BID PRICING, BID IS VOID****

Dillon J. Putnam
Authorized Vendor Representative

Dillon J. Putnam
Typed or Printed Name

Sworn to and subscribed before me this:

The 1st day of September, 2023.

Sandra Bruce
Notary Public

My Commission Expires: 8-25-25

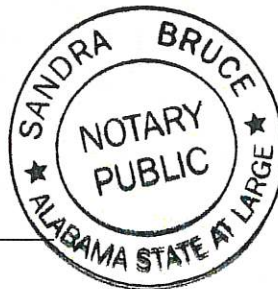



PRINTERS & STATIONERS, INC.

September 1, 2023

TO: Franklin County Commission
PO Box 1028
Russellville, AL 35653

BID FOR: "GENERAL OFFICE SUPPLIES"
DISCOUNT: 34.1%* OFF 2023-2024 CATALOG

This is to inform the Franklin County Commission that Printers & Stationers, Inc. will honor the conditions of Bid for "General Office Supplies" to include a time period of October 1, 2023 through September 30, 2024.

*Plug-ins, electronics, camera, inkjet & laser cartridges, copier toner, drums and all Lexmark, HP, Epson, Brother products and all audio visual products discount is 19.1%.

*Call for pricing on furniture, printing and paper

RESIGNATION OF ACCOUNTANT/PAYABLE CLERK

It is on motion of Mr. Chris Wallace, second by Mr. David Hester unanimously ordered, adjudged and decreed by the Board to approve the resignation of Accountant/Payable Clerk, Brooke King effective October 13, 2023.

Letter as follows:

Brooke King

57 Steien Drive

Russellville, AL 35654

September 5, 2023

Probate Judge Barry Moore and Franklin County Commissioners,

It has been an honor and privilege to work with Probate Judge Barry Moore, County Commissioners, County Administrator Leah Mansell, department heads, and county employees for the past four years. I consider it a blessing to have worked with all of you.

I have accepted the Senior Accountant position with NACOLG and am therefore submitting my resignation with my last day of employment being effective October 13, 2023. It is not a decision that was made lightly because of the wonderful people that I have worked with and for. It was an extremely tough decision to make, but I feel like this is an opportunity that I could not pass up.

Please feel free to call me at any time if my help is needed. Thank you all for the opportunity given to me four years ago and for the wonderful years of working for the Franklin County Commission.

Sincerely,

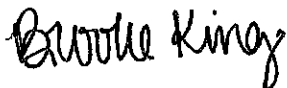
A handwritten signature in black ink that reads "Brooke King". The signature is written in a cursive, slightly slanted style.

Brooke King

ADVERTISE FOR ACCOUNTANT/PAYABLE CLERK

It is on motion of Mr. Jason Miller, second by Mr. Joseph Baldwin unanimously ordered, adjudged and decreed by the Board to approve to advertise for the Accountant/Payable Clerk position.

Letter as follows:



FRANKLIN COUNTY COMMISSION

P.O. Box 1028 • RUSSELLVILLE, AL 35653
PHONE (256) 332-8850 • FAX (256) 332-8855

Barry Moore, Chairman
Chris Wallace, District I
Jason Miller, District II
Joseph Baldwin, District III
David Hester, District IV
Leah Mansell, Administrator

September 15, 2023

Judge Moore and Commissioners,

I am requesting to advertise for the Accountant/Payable Clerk position in the Commission office due to the resignation of Brooke King, effective October 13, 2023. Thank you for your consideration in this matter.

Sincerely,

A handwritten signature in cursive script that reads "Leah Mansell".

Leah Mansell
County Administrator
Franklin County Commission

HIGHWAY DEPARTMENT

FMLA LEAVE FOR EMPLOYEE

It is on motion of Mr. David Hester, second by Mr. Chris Wallace, unanimously ordered, adjudged and decreed by the Board to approve the FMLA leave for Lila Duncan effective August 21, 2023 and ending October 2, 2023.

Letter as follows:

COUNTY ENGINEER
Jason Baggett



TELEPHONE - (256) 332-8434
EMAIL - jasonb@franklincountyal.org

Franklin County Highway Department
P.O. BOX 717
RUSSELLVILLE, ALABAMA 35653

September 8, 2023

Honorable Barry Moore
Chairman
Franklin County Commission
P.O. Box 1028
Russellville, AL 35653

RE: FMLA Leave – Lila Duncan

Dear Judge Moore:

This letter is to inform you and the Franklin County Commission that Lila Duncan is requesting to be placed on FMLA effective August 21, 2023, and is anticipated to return to work on October 2, 2023.

If you have any questions or need any additional information, please inform me.

Sincerely,

A handwritten signature in blue ink that reads "Jason Baggett".

Jason Baggett, PE
County Engineer

Cc: File

DECLARE VACANCY

It is on motion of Mr. Jason Miller, second by Mr. Chris Wallace, unanimously ordered, adjudged and decreed by the Board to approve to declare a vacancy in the Highway Department due to the death of Micky Montgomery.

SHERIFF'S OFFICE/JAIL

HIRE PERMANENT CORRECTIONS OFFICER/DISPATCHER

It is on motion of Mr. David Hester, second by Mr. Joseph Baldwin, unanimously ordered, adjudged and decreed by the Board to approve to hire permanent Corrections Officer/Dispatcher Renae Halbrooks effective September 13, 2023.

Letter as follows:



SHANNON OLIVER
SHERIFF

FRANKLIN COUNTY SHERIFF'S OFFICE

748 WALNUT GATE ROAD
RUSSELLVILLE, ALABAMA 35654

OFFICE 256-332-8811
JAIL 256-332-8425
FAX 256-332-8816

September 6, 2023

Barry Moore, Chairman
Franklin County Commission
Po Box 1028
Russellville, AL 35653

Gentlemen,

After reviewing applications and conducting interviews, I am hiring Renae Halbrooks permanent full time as Corrections Officer /Dispatcher. Effective September 13, 2023.

Sincerely,

A handwritten signature in black ink, appearing to read "S. Oliver".

Shannon Oliver
Sheriff

HIRE PERMANENT DEPUTY

It is on motion of Mr. Joseph Baldwin, second by Mr. Jason Miller, unanimously ordered, adjudged and decreed by the Board to approve to hire permanent Deputy Dakota Riley as of September 3, 2023.

Letter as follows:



SHANNON OLIVER
SHERIFF

FRANKLIN COUNTY SHERIFF'S OFFICE

748 WALNUT GATE ROAD
RUSSELLVILLE, ALABAMA 35654

OFFICE 256-332-8811

JAIL 256-332-8425

FAX 256-332-8816

9/6/2023

Barry Moore, Chairman
Franklin County Commission
PO Box 1028
Russellville, AL 35653

Gentlemen,

After reviewing applications and conducting interviews, I am hiring Dakota Riley as a permanent full time Deputy Sheriff. Effective September 3, 2023.

Sincerely,

A handwritten signature in black ink, appearing to read "S. Oliver".

Shannon Oliver
Sheriff

JAIL WATER HEATERS BID

It is on motion of Mr. Joseph Baldwin, second by Mr. Jason Miller, unanimously ordered, adjudged and decreed by the Board to approve the bid from Crouch & Sons for the amount of \$51,996.00.

Bid information as follows:



SHANNON OLIVER
SHERIFF

FRANKLIN COUNTY SHERIFF'S OFFICE

748 WALNUT GATE ROAD
RUSSELLVILLE, ALABAMA 35654

OFFICE 256-332-8811
JAIL 256-332-8425
FAX 256-332-8816

September 8, 2023

Barry Moore, Chairman
Franklin County Commission
PO Box 1028
Russellville, AL 35653

Gentlemen,

I am requesting that we accept the bid from Crouch & Sons Plumbing LLC for the purchase and installation of 14 tankless gas water heaters at the jail. I realize that the bid from Crouch & Sons is \$4906.00 higher than MPE Services, in the past we have had issues with MPE giving us one price and at the end of the job charging higher price, we have also had other issues with MPE over pricing parts and tools used on the job.

Sincerely,

A handwritten signature in black ink, appearing to read "S.O.", written over a horizontal line.

Shannon Oliver
Sheriff of Franklin County

Franklin County Commission
BID PROPOSAL FORM

Purchase and Installation of 14 Tankless, Gas Water Heaters at Franklin County Jail

Price Each \$ 3622.31

Total Price \$ 47,090⁰⁰

Projected Delivery Date:

Within 2 weeks from date of order.

Terms of Payment:

50% to purchase the heaters, 50% upon completion of job.

Exceptions/Deviations/Substitutions: (attach additional sheets if necessary)

We were asked to quote these in March. During our site inspection, we found the 14th water heater was only being used as a holding tank. Employees there told us it could be disposed of. Only 13 water heaters are being quoted. If 14 are desired, quote will be \$50,020

Company Name: MPE Services

Street Address: 3311 County Rd 47

Billing Address: 3311 County Rd 47

City, State & Zip: Florence, AL 35030

Contact Person Name & Phone: Angie Hughes 256-766-9439

Email Address: ahughes@callmpe.com

Angie Hughes
Bidder Representative Signature

9-5-23
Date

Bidder's initials AH



MPE Services
 3311 County Rd 47
 Florence, AL 35630
 256-766-9439
 AL Cert# 22283

Estimate 79103761
 Estimate Date 9/5/2023

Heating/Cooling, Plumbing, Electrical
 One Call Does It All!

Billing Address
 Franklin County Sheriffs Office & Jail
 748 Walnut Gate Road
 Russellville, AL 35654 USA

Job Address
 Franklin County Sheriffs Office & Jail
 748 Walnut Gate Road
 Russellville, AL 35654 USA

Description of work

Estimate to remove 13 Rheem tankless water heaters and install 13 new Rheem tankless units. We will also be removing the electric tank type water heater as well. Estimate includes tankless unit, valve kits, and new gas connections for each unit. We may or may not have to redo some of the piping on the venting and water lines. We will haul off all old units. This estimate is for two crews and normal business hours. Estimated for 3 days at \$3,000 per day labor plus materials.

What they thought was the 14th water heater is actually a 40G electric water heater that was only being used for a holding tank. We were told it would be okay to do away with it altogether.

NOTE This was previously bid on 3/5/23. Re-priced parts and estimate for materials is the same.

WARRANTY INFO - Labor warranty 1 year from date of install. Tankless warranty - 5 year parts and heat exchanger (commercial warranty).

Task #	Description	Quantity	Standard Price	Your Price	Total
103 Plumbing Labor	Labor Daily Rate for 2 crews. Estimated for 3 days	3.00	\$3,000.00	\$3,000.00	\$9,000.00
103 Plumbing SPA - 1 visit	<ul style="list-style-type: none"> Priority Service - After Hours Calls at Regular Rates 15% Discount on Parts and Materials One year warranty on all parts repaired 1 Plumbing Maintenance Check to include: Flush and clean water heater, Inspect water heater pop-off, Clean visible clogs at sink and tub stopper, Inspect all visible water lines, Inspect all visible drain lines, Check water pressure/PRV, Inspect all faucets, Basic chrome aerator replacement (<i>replace when needed</i>), Check for water leaks at toilet, Inspect all tub and shower valves, Inspect all water spigots, Inspect operation of sump pump, Inspect water and drain lines for wash machine. 	13.00	\$125.00	\$125.00	\$1,625.00
Misc Material	1 Rheem tankless water heater 1 valve kit gas supply line Copper pipe and fittings(if needed) 4" pipe(if needed)	13.00	\$3,300.00	\$2,805.00	\$36,465.00

Member Savings	\$6,435.00				
		Sub-Total			\$47,090.00
		Tax			\$0.00
		Total Due			\$47,090.00
		Deposit/Downpayment			\$0.00

Thank you for trusting MPE Services for your repairs.
 For your convenience we accept Visa, Master Card, Discover and American Express for an additional 3.5% fee. We also accept a check or cash. Any returned checks will be charged a \$35.00 fee.

Thank you for your business!

This estimate is an approximation and not guaranteed. The estimate is based on information provided from the client regarding project requirements. Anything outside of the scope of work listed will require a written change order to be made and signed by customer. Actual cost may change once all project elements are finalized. Prior to any change of costs, the client will be notified and customer will have to contact the office with approval. Estimate is valid for 30 days unless otherwise stated. Unless explicitly agreed upon prior to work beginning, payment will be due in full upon completion of project. A deposit may be required before work will begin. There is a 3.5% fee for credit/debit card use. Any materials not provided by MPE Services will carry no warranty.



FRANKLIN COUNTY COMMISSION

P.O. Box 1028 • RUSSELLVILLE, AL 35653
PHONE (256) 332-8850 • FAX (256) 332-8855

Barry Moore, Chairman
Chris Wallace, District I
Jason Miller, District II
Joseph Baldwin, District III
David Hester, District IV
Leah Mansell, Administrator

REQUEST FOR BID

Purchase and Installation of 13 Tankless, Gas Water Heaters at Franklin County Jail

Sealed bids marked "Bids for Jail Water Heaters" will be received by the Franklin County Commission at 405 Jackson Avenue North, Russellville, AL or by mail at P.O. Box 1028, Russellville, AL 35653 until **4:00 PM on Wednesday, September 6, 2023.**

Bids will be opened in the County Commission Chambers at the location listed above at the above stated time and date. Time is of the essence in submitting bids and only sealed bids received in the Commission office by the time listed above shall be opened and considered. Bidders and any other interested individuals are invited to attend the bid opening.

Prospective bidders are instructed to read the **General Terms and Conditions** and **Special Terms and Conditions** carefully. Bid addendums will be provided to all bidders, if necessary. Bids must be made in compliance with the guidelines in the sections referred to herein and each page initialed by the bidder representative to denote understanding of such compliance.

If you have any questions concerning terms or conditions, specifications, or any other aspects of the Request for Bid, please contact the following:

Felisha Weeks
Franklin County Jail Administrator
(256)332-8826

Bidder Initials: AH

**Franklin County Commission
General Terms and Conditions**

(PLEASE READ AND INITIAL EACH PAGE)

Preparation and Submission - All bids must be typed or hand written in ink on the attached Bid Proposal Form. Please place the Bid Proposal Form in front of and separated from all other documents included in the bid packet. Bids submitted in pencil and bids not submitted on the Bid Proposal Form will not be considered. All corrections and erasures shall be initialed and dated by the bidder representative. Bids that are submitted without being signed will automatically be rejected.

Bid envelopes must be sealed and must indicate clearly the appropriate bid item and bid opening date, as indicated on the cover sheet of the bid packet. Envelopes containing a "no bid" shall also include the words, "NO BID" on the outside of the envelope. Facsimiles and emails will not be accepted. Bids submitted by "Express/Overnight" services must be in a separate inner envelope or package sealed and identified as stated above, and must be delivered prior to the bid opening time. The Commission will not be responsible in the event the U.S. Postal Service or any other courier system fails to deliver the proposal to the Commission office by the deadline stated in the bid request.

Bonds - The Commission reserves the right to require a performance bond from a successful bidder as permitted under Alabama law. Failure to submit bond when required will result in rejection of the bid. Bidders must extend unit price times estimated quantities provided in specifications to determine appropriate bid bond/check amount.

Other Compliance/Legal Assurances - The Commission provides equal opportunities for all businesses and does not discriminate against any vendor regardless of race, sex, creed, age, disability, national origin or religion in consideration for an award. Bidders must abide by the provision of the Americans with Disabilities Act of 1990 and assure that in connection with the performance of work under this agreement that they are an equal opportunity employer and do not discriminate on the basis of race, sex, creed, age, disability, national origin or religion.

All contractors and employees are subject to Franklin County's drug-free workplace policy in substantial compliance with the Alabama Drug-Free Workplace Act of 1995, Code of Alabama 1975, SS 25-5-334 et seq.

All bidders must comply with applicable sections of the Alabama Competitive Bid Law, Code of Alabama 1975.

The Commission assumes no legal liability to purchase items or services under any contract.

Bidder's Initials

AH

The successful bidder agrees, by entering into this contract, to defend, indemnify and hold harmless Franklin County, Franklin County Commission, its officers and employees from any and all causes of actions or claims of damages arising out of or related to bidder's performance of this contract.

Bid Prices – All bid amounts shall be submitted on the attached Bid Proposal Form. Prices quoted shall be delivered prices, exclusive of all federal or state excise, sales, and manufacturer's taxes. The Commission will assume no transportation or handling charges other than specified in this bid. If there are discrepancies between unit prices quoted and extensions, the unit price will prevail. Prices quoted shall remain firm for a minimum of 30 days from the date of opening of the bid, unless so stated differently in the bid.

Bid Exceptions/Deviations/Substitutions – The attached specifications are being provided to potential bidders as guidelines, which describe the type and quality of equipment, supply, and/or service that the Commission is seeking to purchase. The name of a certain brand, make, manufacturer, or definite specification is to denote the quality, standard, general style, type or character of the item desired but does not restrict the bidder to the specified brand, make, manufacturer or specification names. The bidder must indicate compliance or list detailed exceptions to each specification item for consideration. The bidder must provide satisfactory proof that the alternative product is, in fact, equal to the product described in the specifications. Any substitution of an item during the term of this bid (if applicable) must be of equal or better quality than the item bid. Failure to comply with any part of this provision could be cause for rejection of the bid.

Bid Award/Rejection – All bids will be awarded to the lowest responsive and responsible bidder. This determination may involve all or some of the following factors: price, conformity to specifications, financial ability to meet the contract, previous performance, facilities and equipment, availability of repair parts, experience, delivery promise, terms of payments, compatibility as required, other costs, and other objective and accountable factors which are reasonable. When responsive and responsible bids are equal, a local vendor shall be favored. Unless Special Terms and Conditions of the bid specify otherwise, the Commission reserves the right to make an award in whole or part to one or more bidders whenever deemed necessary and in the best interest of the Commission. The Commission reserves the right to accept or reject any or all items covered in the request, or any portion(s) thereof, waive formalities, re-advertise and/or take such other steps deemed necessary and in the best interest of the Commission. Bidders may be disqualified and bid proposals may be rejected for any of (but not limited to) the following causes:

- a. Failure to use the bid forms furnished by the Commission
- b. Lack of signature by an authorized representative on the Bid Proposal Form.
- c. Failure to properly complete the bid form.
- d. Evidence of collusion among bidders.
- e. Unauthorized alteration of the bid form.
- f. Failure to furnish performance bond, as required.
- g. Inclusion of an "escalator clause" unless so stipulated in the Special Terms and Conditions.

**Franklin County Commission
Special Terms and Conditions**

Term – The bid shall be valid for a period through December 31, 2023.

Delivery – Delivery shall be guaranteed within **90 days** of purchase order issuance date. Delivery shall be to the appropriate department ordering the goods through issuance of a purchase order. Bidder's projected delivery date shall be specified on the Bid Proposal Form.

Warranty – The bidder shall assume full responsibility for warranty of all components of the equipment. A statement shall be attached with the proposal setting out the conditions of the warranty. The manufacturer's standard warranty shall be furnished.

Bidder's Initials

AH

Franklin County Commission
BID PROPOSAL FORM

Purchase and Installation of 14 Tankless, Gas Water Heaters at Franklin County Jail

Price Each \$ 3714.⁰⁰

Total Price \$ 51996.⁰⁰

Projected Delivery Date:

14-60 days from award date

Terms of Payment:

60 days net

Exceptions/Deviations/Substitutions:

(attach additional sheets if necessary)

Company Name: Crouch & Sons Plumbing, LLC

Street Address: 4438 Chisholm Rd, Florence, AL

Billing Address: 4438 Chisholm Road

City, State & Zip: Florence, AL 35630

Contact Person Name & Phone: Laura Crouch 256-766-7770

Email Address: Crouchandsonsplumbingllc@gmail.com



Bidder Representative Signature

9/1/23

Date

Bidder's Initials





FRANKLIN COUNTY COMMISSION

P.O. Box 1028 • RUSSELLVILLE, AL 35653
PHONE (256) 332-8850 • FAX (256) 332-8855

Barry Moore, Chairman
Chris Wallace, District I
Jason Miller, District II
Joseph Baldwin, District III
David Hester, District IV
Leah Mansell, Administrator

REQUEST FOR BID

Purchase and Installation of 13 Tankless, Gas Water Heaters at Franklin County Jail

Sealed bids marked "Bids for Jail Water Heaters" will be received by the Franklin County Commission at 405 Jackson Avenue North, Russellville, AL or by mail at P.O. Box 1028, Russellville, AL 35653 until **4:00 PM on Wednesday, September 6, 2023.**

Bids will be opened in the County Commission Chambers at the location listed above at the above stated time and date. Time is of the essence in submitting bids and only sealed bids received in the Commission office by the time listed above shall be opened and considered. Bidders and any other interested individuals are invited to attend the bid opening.

Prospective bidders are instructed to read the **General Terms and Conditions** and **Special Terms and Conditions** carefully. **Bid addendums** will be provided to all bidders, if necessary. Bids must be made in compliance with the guidelines in the sections referred to herein and each page initialed by the bidder representative to denote understanding of such compliance.

If you have any questions concerning terms or conditions, specifications, or any other aspects of the Request for Bid, please contact the following:

Felisha Weeks
Franklin County Jail Administrator
(256)332-8826

Handwritten initials "LC" in black ink.

**Franklin County Commission
General Terms and Conditions**

(PLEASE READ AND INITIAL EACH PAGE)

Preparation and Submission - All bids must be typed or hand written in ink on the attached Bid Proposal Form. Please place the Bid Proposal Form in front of and separated from all other documents included in the bid packet. Bids submitted in pencil and bids not submitted on the Bid Proposal Form will not be considered. All corrections and erasures shall be initialed and dated by the bidder representative. Bids that are submitted without being signed will automatically be rejected.

Bid envelopes must be sealed and must indicate clearly the appropriate bid item and bid opening date, as indicated on the cover sheet of the bid packet. Envelopes containing a "no bid" shall also include the words, "NO BID" on the outside of the envelope. Facsimiles and emails will not be accepted. Bids submitted by "Express/Overnight" services must be in a separate inner envelope or package sealed and identified as stated above, and must be delivered prior to the bid opening time. The Commission will not be responsible in the event the U.S. Postal Service or any other courier system fails to deliver the proposal to the Commission office by the deadline stated in the bid request.

Bonds - The Commission reserves the right to require a performance bond from a successful bidder as permitted under Alabama law. Failure to submit bond when required will result in rejection of the bid. Bidders must extend unit price times estimated quantities provided in specifications to determine appropriate bid bond/check amount.

Other Compliance/Legal Assurances - The Commission provides equal opportunities for all businesses and does not discriminate against any vendor regardless of race, sex, creed, age, disability, national origin or religion in consideration for an award. Bidders must abide by the provision of the Americans with Disabilities Act of 1990 and assure that in connection with the performance of work under this agreement that they are an equal opportunity employer and do not discriminate on the basis of race, sex, creed, age, disability, national origin or religion.

All contractors and employees are subject to Franklin County's drug-free workplace policy in substantial compliance with the Alabama Drug-Free Workplace Act of 1995, Code of Alabama 1975, SS 25-5-334 et seq.

All bidders must comply with applicable sections of the Alabama Competitive Bid Law, Code of Alabama 1975.

The Commission assumes no legal liability to purchase items or services under any contract.

Bidder's Initials FC

**Franklin County Commission
Special Terms and Conditions**

Term – The bid shall be valid for a period through December 31, 2023.

Delivery – Delivery shall be guaranteed within **90 days** of purchase order issuance date. Delivery shall be to the appropriate department ordering the goods through issuance of a purchase order. Bidder's projected delivery date shall be specified on the Bid Proposal Form.

Warranty – The bidder shall assume full responsibility for warranty of all components of the equipment. A statement shall be attached with the proposal setting out the conditions of the warranty. The manufacturer's standard warranty shall be furnished.

Bidder's Initials



The successful bidder agrees, by entering into this contract, to defend, indemnify and hold harmless Franklin County, Franklin County Commission, its officers and employees from any and all causes of actions or claims of damages arising out of or related to bidder's performance of this contract.

Bid Prices – All bid amounts shall be submitted on the attached Bid Proposal Form. Prices quoted shall be delivered prices, exclusive of all federal or state excise, sales, and manufacturer's taxes. The Commission will assume no transportation or handling charges other than specified in this bid. If there are discrepancies between unit prices quoted and extensions, the unit price will prevail. Prices quoted shall remain firm for a minimum of 30 days from the date of opening of the bid, unless so stated differently in the bid.

Bid Exceptions/Deviations/Substitutions – The attached specifications are being provided to potential bidders as guidelines, which describe the type and quality of equipment, supply, and/or service that the Commission is seeking to purchase. The name of a certain brand, make, manufacturer, or definite specification is to denote the quality, standard, general style, type or character of the item desired but does not restrict the bidder to the specified brand, make, manufacturer or specification names. The bidder must indicate compliance or list detailed exceptions to each specification item for consideration. The bidder must provide satisfactory proof that the alternative product is, in fact, equal to the product described in the specifications. Any substitution of an item during the term of this bid (if applicable) must be of equal or better quality than the item bid. Failure to comply with any part of this provision could be cause for rejection of the bid.

Bid Award/Rejection – All bids will be awarded to the lowest responsive and responsible bidder. This determination may involve all or some of the following factors: price, conformity to specifications, financial ability to meet the contract, previous performance, facilities and equipment, availability of repair parts, experience, delivery promise, terms of payments, compatibility as required, other costs, and other objective and accountable factors which are reasonable. When responsive and responsible bids are equal, a local vendor shall be favored. Unless Special Terms and Conditions of the bid specify otherwise, the Commission reserves the right to make an award in whole or part to one or more bidders whenever deemed necessary and in the best interest of the Commission. The Commission reserves the right to accept or reject any or all items covered in the request, or any portion(s) thereof, waive formalities, re-advertise and/or take such other steps deemed necessary and in the best interest of the Commission. Bidders may be disqualified and bid proposals may be rejected for any of (but not limited to) the following causes:

- a. Failure to use the bid forms furnished by the Commission
- b. Lack of signature by an authorized representative on the Bid Proposal Form.
- c. Failure to properly complete the bid form.
- d. Evidence of collusion among bidders.
- e. Unauthorized alteration of the bid form.
- f. Failure to furnish performance bond, as required.
- g. Inclusion of an "escalator clause" unless so stipulated in the Special Terms and Conditions.

Bidder's Initials

RC

Bid Bond

KNOW ALL MEN BY THESE PRESENTS, that we

Crouch and Sons Plumbing, LLC, 4438 Chisholm Rd, Florence, AL 35630

(Here insert full name and address or legal title of Contractor)

as Principal, hereinafter called Principal, and,

FCCI Insurance Company, 6300 University Parkway, Sarasota, FL 34240-8424

(Here insert full name and address or legal title of Surety)

a corporation duly organized under the laws of the State of FLORIDA

as Surety, hereinafter called the Surety, are held and firmly bound unto

Franklin County Commission, 405 Jackson Ave North, Russellville, AL 35654

(Here insert full name and address or legal title of Corporation)

as Obligee, hereinafter called the Obligee, in the sum of

Fifty-Five Thousand Dollars

Dollars (\$ 55,000),

for the payment of which sum well and truly to be made, the said Principal and the said Surety, bind ourselves, our heirs, executors, administrators, successors and assigns, jointly and severally, firmly by these presents.

WHEREAS, the Principal has submitted a bid for

Replacing 13 tankless water heaters with 14 tankless water heaters at the Franklin County Jail

(Here insert full name and address description of project)

NOW THEREFORE, if the obligee shall accept the bid of the principal and the principal shall enter into Contract with the Obligee in accordance with the terms of such bid, and give such bond or bonds as may be specified in the bidding or Contract Documents with good and sufficient surety for the faithful performance of such Contract and for the prompt payment of labor and material furnished in the prosecution thereof, or in the event of the failure of the Principal to enter such Contract and give such bond or bonds, if the Principal shall pay to the Obligee the difference not to exceed the penalty hereof between the amount specified in said bid and such larger amount for which the obligee may in good faith contract with another party to perform the Work covered by said bid, then this obligation shall be null and void, otherwise to remain in full force and effect.

Signed and sealed this 5th day of September, 20 23



(Witness)

Crouch and Sons Plumbing, LLC

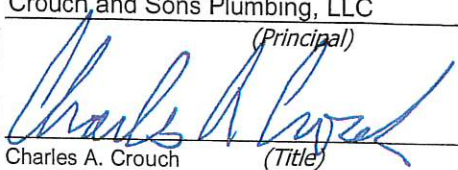
(Principal) (Seal)

Charles A. Crouch (Title) Member

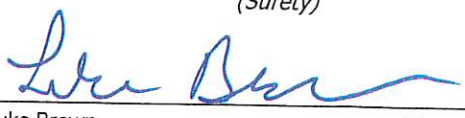

(Witness)

FCCI Insurance Company

(Surety) (Seal)

Luke Brown Attorney-In-Fact



GENERAL POWER OF ATTORNEY

Know all men by these presents: That the FCCI Insurance Company, a Corporation organized and existing under the laws of the State of Florida (the "Corporation") does make, constitute and appoint:

Tyson Johnson; Kirby Allen; Bryan Thornton; Ashley Thompson; Victoria DeVaney; Luke Brown; Nick Hester; Brant Bishop

Each, its true and lawful Attorney-In-Fact, to make, execute, seal and deliver, for and on its behalf as surety, and as its act and deed in all bonds and undertakings provided that no bond or undertaking or contract of suretyship executed under this authority shall exceed the sum of (not to exceed \$30,000,000.00): \$30,000,000.00

This Power of Attorney is made and executed by authority of a Resolution adopted by the Board of Directors. That resolution also authorized any further action by the officers of the Company necessary to effect such transaction.

The signatures below and the seal of the Corporation may be affixed by facsimile, and any such facsimile signatures or facsimile seal shall be binding upon the Corporation when so affixed and in the future with regard to any bond, undertaking or contract of surety to which it is attached.

In witness whereof, the FCCI Insurance Company has caused these presents to be signed by its duly authorized officers and its corporate Seal to be hereunto affixed, this 23rd day of July, 2020.

Attest: Christina D. Welch
Christina D. Welch, President
FCCI Insurance Company



Christopher Shoucair
Christopher Shoucair,
EVP, CFO, Treasurer, Secretary
FCCI Insurance Company

State of Florida
County of Sarasota

Before me this day personally appeared Christina D. Welch, who is personally known to me and who executed the foregoing document for the purposes expressed therein.

My commission expires: 2/27/2027

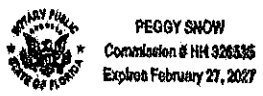

Peggy Snow
Notary Public

State of Florida
County of Sarasota

Before me this day personally appeared Christopher Shoucair, who is personally known to me and who executed the foregoing document for the purposes expressed therein.

My commission expires: 2/27/2027

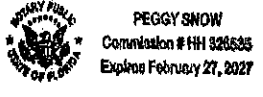

Peggy Snow
Notary Public

CERTIFICATE

I, the undersigned Secretary of FCCI Insurance Company, a Florida Corporation, DO HEREBY CERTIFY that the foregoing Power of Attorney remains in full force and has not been revoked; and furthermore that the February 27, 2020 Resolution of the Board of Directors, referenced in said Power of Attorney, is now in force.

Dated this 5th day of September, 2023

Christopher Shoucair
Christopher Shoucair, EVP, CFO, Treasurer, Secretary
FCCI Insurance Company

CROUCH & SONS PLUMBING, LLC.

4438 Chisholm Rd, Florence, AL 35630

PH: 256-766-7770 FX: 256-766-0056

crouchandsonsplumbingllc@gmail.com

Franklin County Jail Bid

Bid is to remove 13 Rheem tankless water heaters, one 50 gallon electric tank - type water heater, and 4 recirculation pumps. Rework recirculating line and install new recirculating pump, 4 balancing valves, 1 aquastat, 1 thermometer, 2 dry wells, 1 two inch check valve, and 4 three quarter inch check valves. (These are necessary to ensure proper delivery of hot water throughout the system.) Install 14 Navien 240s tankless water heaters, and add 2 common vent kits for added heaters.

Subcontractor(Crouch and Sons Plumbing):

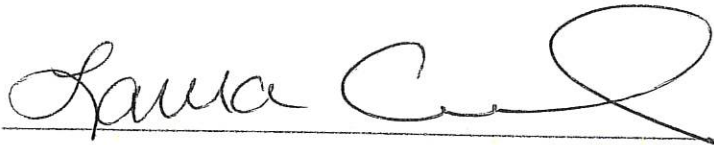

NPE-2 Series Tankless Water Heaters Specification Sheet

Premium Condensing Tankless Gas Water Heater

- Certified design according to ANSI Z21.10.3 - CSA 4.3 latest standards for both indoor or outdoor installations (with optional Outdoor Vent Kit)
- Compatible with 1/2" gas pipe up to a length of 24 ft* (*see Installation Manual for additional information)
- Compatible with 2" PVC vent up to 75 ft** and 150 ft** using 3" PVC vent (**with no elbows)
- Designed for use in Residential and Commercial applications (see below for available models and warranty terms)
- Gas Input Ranges
 - NPE-180A2/S2 - 150,000 to 10,000 BTU/h
 - NPE-210A2/S2 - 180,000 to 12,000 BTU/h
 - NPE-240A2/S2 - 199,900 to 13,300 BTU/h
 - NPE-150S2 - 120,000 to 18,000 BTU/h
- Hot Water Flow Rate Capacity (*based on 35°F temperature rise)
 - NPE-180A2/S2 8.4 GPM
 - NPE-210A2/S2 10.1 GPM
 - NPE-240A2/S2 11.2 GPM**
 - NPE-150 S2 6.8 GPM
- TDR (Turn Down Ratio) up to 15:1
- Dual Primary and Secondary Stainless Steel Heat Exchangers for optimum efficiency and durability
- Built-In - Advanced Multi-Lines Control Panel with setup wizard allows adjustment of temperature settings and displays of operating status and error codes
- **ComfortFlow™** Technology. "A2" models come included with built-in 0.5 gallon Buffer Tank and Recirculation Pump to provide maximum comfort
- **INTELLIGENT Preheating** - recognizes hot water usage patterns to intelligently provide hot water when needed (optional for "S" models)
- **Temperature Options** - available temperature settings for Residential applications range from 97°F up to 140°F with high temperature Commercial mode capable of up to 185°F
- **Ready-Link Cascade Compatible** for up to 32 units for increased hot water production
- **Common Vent Compatible** - allows for cascade systems to use a single exhaust and/or intake pipe for up to 12 units with the use of the Common Vent Backflow Damper Collar Kit (#30014367A)
- Compatible with **Navilink**. Wi-Fi Control (#PBCM-AS-001)
- **Freeze Protection** - maintains normal operation during freezing ambient temperatures down to -5°F (standard on all models)
- **Uniform Energy Factor Ratings** for NG and LP units
 - NPE-180A2/210A2/240A2 - 0.95 UEF
 - NPE-180S2/210S2/240S2 - 0.96 UEF
 - NPE-150S2 - 0.93 UEF
- Compatible with **Natural Gas (NG)** and **Propane (LPG)** (***) (***) requires installation of Included Field Conversion Kit by a qualified gas servicer)
- Approved for Installations on **Manufactured Homes**
- Optional **NaviCirc** Crossover Valve Compatible
- Certified by CSA, NSF 5, AHRI, AB1953 CA Low Lead, SCAQMD (Rule 1146.2 Type 1 - Complies with 14 ng/l or 20 ppm NOx @ 3% O2)
- **15-Year Heat Exchanger and 5-Year Parts Warranty (Residential)******
8-Year Heat Exchanger and 5-Year Parts Warranty (Commercial)**** (**** see Navien Limited Warranty)
- **Optional accessories** are available (see below)



Sleek Design
Compatible with
2" PVC and 1/2" Gas Pipe

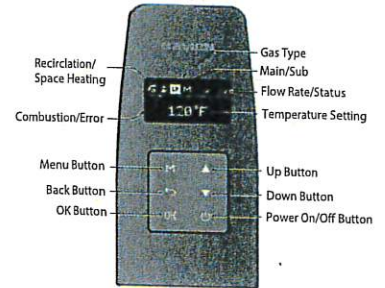

Built-In Control Panel
with Diagnostics

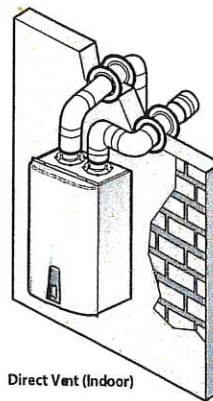

Direct Vent (Indoor)

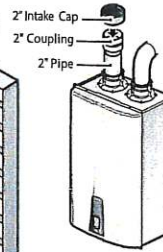

Non-Direct Vent (Indoor)

Indoor and Outdoor Venting Options

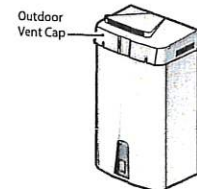

Non-Direct Vent (Outdoor)



Job Name: _____
 Location: _____
 Engineer: _____
 Wholesaler: _____
 Contractor: _____
 Model No.: _____
 Submitted to: _____

Remote Controller (30022717B)	Plumb Easy Valve Set (3/4") (30009323A - Lead Free) (30025812A - for Pipe Cover)	Condensate Neutralizer (GXXX001322 - Single Unit) (GXXX001324 - Up to 6 Units) (GXXX001325 - Up to 16 Units)	Ready-Link Communication Cable (GXXX000546)	Outdoor Vent Kit (30025801A)	External Pump Wire (GXXX001319)	3" Vent Termination Caps and Wall Flanges (GXXX3873B)

Premium Condensing
Tankless Gas Water Heater

NPE-2 Series Tankless Water Heaters
Specification Sheet

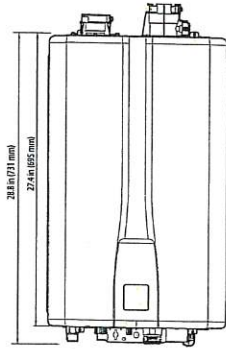

Overhead View

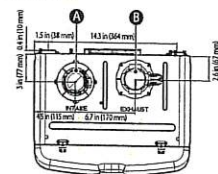

NPE-180A2/ 210A2/240A2

SupplyConnections

Description	Diameter
A Air Intake	2 in
B Exhaust Gas Vent	2 in
C Hot Water Outlet	3/4 in
D Gas Inlet	3/4 in
E Recirculation Inlet	3/4 in
F Condensate Outlet	1/2 in
G Cold Water Inlet	3/4 in

SupplyConnections

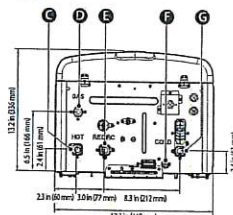

NPE-150S2/180S2/210S2/240S2

SupplyConnections

Description	Diameter
A Air Intake	2 in
B Exhaust Gas Vent	2 in
C Hot Water Outlet	3/4 in
D Gas Inlet	3/4 in
E Condensate Outlet	1/2 in
F Cold Water Inlet	3/4 in

SupplyConnections

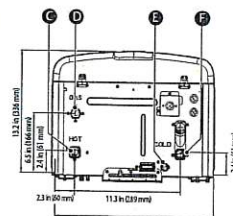

Item	NPE-150S2	NPE-180A2	NPE-180S2	NPE-210A2	NPE-210S2	NPE-240A2	NPE-240S2
Heat Capacity (Input)	Natural Gas, Propane Gas 18,000-120,000 BTU/H	10,000-150,000 BTU/H		12,000-180,000 BTU/H		13,300-199,900 BTU/H	
Uniform Energy Factor	UEF (for NG & LP) 0.93	0.95	0.96	0.95	0.96	0.95	0.96
Flow Rate (D+H)	35 °F (19 °C) Temp Rise 6.8 GPM (25.8 L/m)	8.4 GPM (32 L/m)		10.1 GPM (38 L/m)		11.2 GPM (42 L/m)	
	45 °F (25 °C) Temp Rise 5.3 GPM (20 L/m)	6.5 GPM (25 L/m)		7.8 GPM (30 L/m)		8.7 GPM (33 L/m)	
	67 °F (36 °C) Temp Rise 3.4 GPM (13 L/m)	4.3 GPM (16 L/m)	4.4 GPM (17 L/m)	5.1 GPM (19 L/m)	5.3 GPM (20 L/m)	5.6 GPM (21 L/m)	5.8 GPM (22 L/m)
Dimensions	17.3 in (W) x 27.4 in (H) x 13.2 in (D)						
Weight	62 lbs (28 kg)	73 lbs (33 kg)	68 lbs (31 kg)	77 lbs (35 kg)	73 lbs (33 kg)	77 lbs (35 kg)	73 lbs (33 kg)
Installation Type	Indoor or Outdoor Wall-Hung						
Venting Type	Forced Draft Direct Vent						
Ignition	Electronic Ignition						
Water Pressure	15-150 PSI						
Natural Gas Supply Pressure (from source)	3.5 in WC-10.5 in WC						
Propane Gas Supply Pressure (from source)	8 in WC-13 in WC						
Natural Gas Manifold Pressure (min-max)	-0.04 in WC - -0.40 in WC	-0.03 in WC - -0.55 in WC		-0.03 in WC - -0.76 in WC		-0.03 in WC - -0.96 in WC	
Propane Gas Manifold Pressure (min-max)	-0.03 in WC - -0.40 in WC	-0.02 in WC - -0.55 in WC		-0.02 in WC - -0.76 in WC		-0.02 in WC - -0.96 in WC	
Minimum Flow Rate	0.5 GPM (1.9 L/m), < 0.01 GPM (0.04 L/m) option for "A2" models*						
Connection Sizes	Cold Water Inlet	3/4 in NPT					
	Hot Water Outlet	3/4 in NPT					
	Gas Inlet	3/4 in NPT					
Power Supply	Main Supply	120 V AC, 60 Hz					
	Maximum Power Consumption	200 W (max 2 A), 350 W (max 4 A) with external pump connected					
Materials	Casing	Cold Rolled Carbon Steel					
	Heat Exchangers	Primary Heat Exchanger: Stainless Steel Secondary Heat Exchanger: Stainless Steel					
Venting	Exhaust	2 in or 3 in PVC, CPVC, Approved Polypropylene and stainless steel 2 in or 3 in Special Gas Vent Type BH (Class II, A/B/C)					
	Intake	2 in or 3 in PVC, CPVC, Approved Polypropylene and stainless steel 2 in or 3 in Special Gas Vent Type BH (Class II, A/B/C)					
	Vent Clearances	0 in to combustibles					
High Elevation	10,100 feet for both NG or LP gas. Please refer to Installation Manual for additional details and instructions.						
Safety Devices	Flame Rod, APS, Ignition Operation Detector, Water Temperature High Limit Switch, Exhaust Temperature High Limit Sensor, Power Surge Fuse, Burner High Limit Fuse, Vent Installation Detector (VID)						

* Available for "A2" models configured in an optional ComfortFlow recirculation mode. Energy consumption will increase when the system is configured for recirculation.

Gas-fired, tankless, condensing, wall-mounted water heater(s) shall be direct vent NPE-2 Series models as manufactured by Navien, Inc. and are certified by CSA International to the latest edition of ANSI standard Z21.10.3/CSA 4.3. Water heater(s) shall have a 15(5)-year limited Heat Exchanger warranty and 5(3)-year limited Parts warranty (8(5)-year Heat Exchanger and 5(3)-year Parts for Commercial use) per Navien Limited Warranty. Unit(s) shall be designed to burn natural gas and can be for use with propane when a Field Conversion Kit is installed. _____ (qty) NPE water heater(s) shall have a nominal flow rate capacity of _____ GPM/GPH at _____ °F rise with rated input of _____ BTU/hr. Water heater(s) shall be vented with 2" Schedule 40/80 PVC/CPVC, approved polypropylene and stainless steel vent pipe at a distance not to exceed 75' (or equivalent) with each elbow equal to 8' of pipe length or 3" Schedule 40/80 PVC/CPVC, approved polypropylene and stainless steel vent pipe at a distance of 150' (or equivalent) with each elbow equal to 5' of pipe length. Water heater(s) is rated for 150 PSI working water pressure and 300 PSI test pressure. Gas supply pressure shall be 3.5" to 10.5" WC for natural gas and 8.0" to 13.0" WC for propane. Unit(s) shall have a steel case, dual 0.6 gallon for the NPE-150S2, 1.0 gallon for the NPE-180A2 model (0.7 gallons for NPE-180S2 model), 1.2 gallons for the NPE-210A2/NPE-240A2 models (0.7 and 0.9 gallons for NPE-210S2 and NPE-240S2 models respectively), and a condensate collector. The NPE-180A2 model weighs 73 lbs (NPE-180S2 weighs 68 lbs), and the NPE-210A2/NPE-240A2 models weigh 77 lbs (NPE-210S2 and NPE-240S2 weigh 73 lbs) and The NPE-150S2 weigh 62 lbs. Unit(s) shall include features such as an adjustment for installations at high elevation, temperature lockout, and temperature commercial applications. All NPE "A2" models shall include an internal circulation pump and 0.5-gallon buffer tank. The water heater(s) shall be controlled by an internal circuit board that monitors the inlet and outlet temperatures with installed thermistors, sensing and controlling flow rate to set point temperature with air-fuel ratio controls in order to maintain thermal combustion efficiency. Unit(s) shall include safety features such as flame sensor system, high limit sensors, overheat prevention device, freeze protection mode, and fan motor rotation detector. Multi-system (cascade) applications that require 2 to 32 units shall be installed by connecting the units using cable only connections (Ready Link). The water heater(s) exceeds the energy efficiency requirements of ASHRAE 90.1-2010 and is listed by SCAQMD rule 1146.2 (Type 1) for Low NOx that complies with 14 ng/J or 20 ppm NOx requirements @ 3% O2.

*Navien reserves the right to change specifications at any time without prior notice

ASTRO 2 | THREE SPEED CIRCULATORS | SUBMITTAL

File No: 10,584
Date: MARCH 03, 2017
Supersedes: 10,584
Date: APRIL 03, 2014

Job: _____ Representative: _____

_____ Ordered by: _____ Date: _____

Engineer: _____ Submitted by: _____ Date: _____

Contractor: _____ Approved by: _____ Date: _____

TECHNICAL DATA

Certification: ETL listed for US and Canada (conforms to UL STD.778 certified to CSA STD. C22.2 NO.108-01)
NSF 372 (for lead free bronze and stainless steel models)

Flow range: 0 - 64 USgpm / 0 - 4.04 l/s

Head range: 0 - 42.0 feet / 0 - 12.8 meters

Maximum fluid temperature: 185°F / 85°C (Astro 286 up to 1.35A)
150°F / 65°C (Astro 286 over 1.35A)
230°F / 110°C† (all others)

Maximum working pressure: 150 psi / 1034 kPa

MATERIALS OF CONSTRUCTION

Pump body: Cast iron (closed systems)
Lead free bronze* (open systems)
Stainless steel* (open systems)

Impeller: Noryl

Shaft: Ceramic

Bearings: Ceramic

Gasket material: EPDM

DIMENSIONS AND WEIGHTS

LEAD FREE BRONZE*	A	B	C	D	E	F	CONNECTION TYPE & SIZE	WEIGHT
Astro 225Bs ½" SWT	5.00 (127)	5.00 (127)	4.13 (105)	—	3.10 (79)	—	Sweat - ½"	6.0 (2.7)
Astro 225Bs ¾" SWT	5.00 (127)	5.00 (127)	4.13 (105)	—	3.10 (79)	—	Sweat - ¾"	6.0 (2.7)
STAINLESS STEEL*	A	B	C	D	E	F	CONNECTION TYPE & SIZE	WEIGHT
Astro 220ssu**	6.00 (152)	5.00 (127)	4.00 (102)	—	3.10 (79)	—	Union - 1¼" NPSM	6.5 (2.9)
Astro 225ssu**	6.00 (152)	5.00 (127)	4.00 (102)	—	3.10 (79)	—	Union - 1¼" NPSM	6.5 (2.9)
Astro 230ss**	6.38 (162)	6.00 (150)	4.00 (102)	4.00 (102)	3.10 (79)	3.25 (80)	Flange - (2) ½" dia. bolt holes	8.0 (3.6)
* Astro 250ss**	6.38 (162)	6.00 (150)	4.00 (102)	4.00 (102)	3.10 (79)	3.25 (80)	Flange - (2) ½" dia. bolt holes	8.0 (3.6)
Astro 210ss**	6.50 (165)	7.25 (184)	4.87 (124)	4.00 (102)	3.60 (91)	3.13 (80)	Flange - (2) ½" dia. bolt holes	10.1 (4.6)
Astro 280ss (230V)**	6.50 (165)	6.75 (171)	4.87 (124)	4.00 (102)	3.60 (91)	3.13 (80)	Flange - (2) ½" dia. bolt holes	10.1 (4.6)
Astro 286ss**	6.50 (165)	6.38 (162)	4.87 (124)	4.00 (102)	3.60 (91)	3.13 (80)	Flange - (2) ½" dia. bolt holes	10.1 (4.6)
Astro 290ss**	8.50 (216)	6.65 (169)	5.20 (132)	4.00 (102)	3.60 (91)	3.45 (88)	Flange - (2) ½" dia. bolt holes	13.2 (6.0)
CAST IRON	A	B	C	D	E	F	CONNECTION TYPE & SIZE	WEIGHT
Astro 230ci**	6.38 (162)	6.00 (150)	4.00 (102)	4.00 (102)	3.10 (79)	3.25 (80)	Flange - (2) ½" dia. bolt holes	8.0 (3.6)
Astro 230ci-R**	6.38 (162)	5.63 (137)	4.00 (102)	4.00 (102)	3.10 (79)	3.25 (80)	Flange - (2) ½" dia. bolt holes	8.0 (3.6)
Astro 250ci**	6.38 (162)	6.00 (150)	4.00 (102)	4.00 (102)	3.10 (79)	3.25 (80)	Flange - (2) ½" dia. bolt holes	8.0 (3.6)
Astro 250ci-R**	6.38 (162)	5.63 (137)	4.00 (102)	4.00 (102)	3.10 (79)	3.25 (80)	Flange - (2) ½" dia. bolt holes	8.0 (3.6)
Astro 210ci**	6.50 (165)	7.25 (184)	4.87 (124)	4.00 (102)	3.60 (91)	3.13 (80)	Flange - (2) ½" dia. bolt holes	10.1 (4.6)
Astro 280ci (230V)**	6.50 (165)	6.38 (162)	4.87 (124)	4.00 (102)	3.60 (91)	3.13 (80)	Flange - (2) ½" dia. bolt holes	10.1 (4.6)
Astro 286ci**	6.50 (165)	6.38 (162)	4.87 (124)	4.00 (102)	3.60 (91)	3.13 (80)	Flange - (2) ½" dia. bolt holes	10.1 (4.6)
Astro 290ci**	8.50 (216)	6.65 (169)	5.20 (132)	4.00 (102)	3.60 (91)	3.45 (88)	Flange - (2) ½" dia. bolt holes	13.2 (6.0)

NOTE: All dimensions are in inches (mm) and weights in lbs (kg).

* Certified <0.25 weighted average percent lead and complies with California Health and Safety Code Section 116875 (commonly known as AB 1953).

** Removable check valve installed at pump outlet.

† For open systems, it is recommended that the fluid temperature be less than 150°F (66°C) to avoid precipitation of calcium.

ASTRO 230SS/CI & 250SS/CI

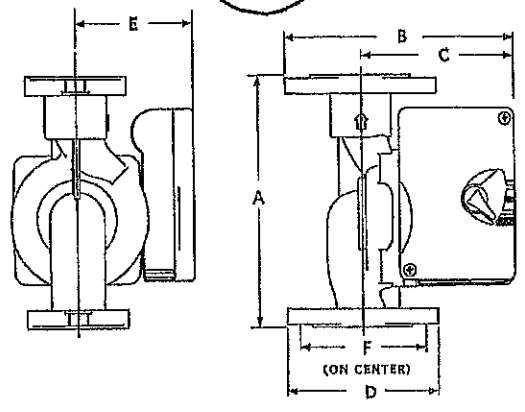

ASTRO 230CI-R & 250CI-R

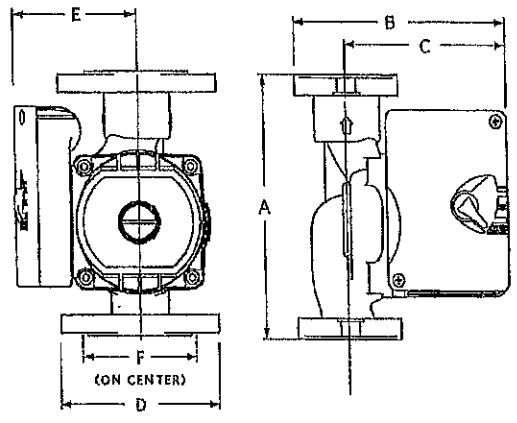

ASTRO 280CI, 290CI/SS & 286CI/SS

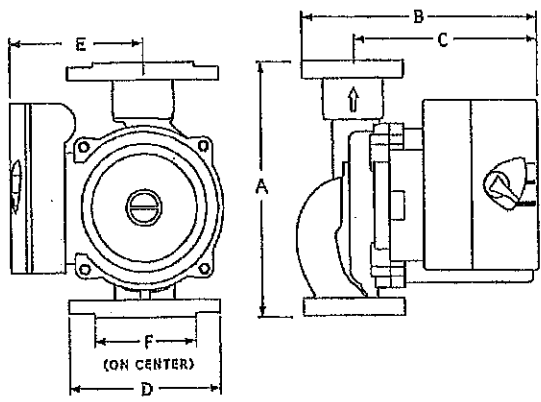

ASTRO 210CI/SS & 280SS

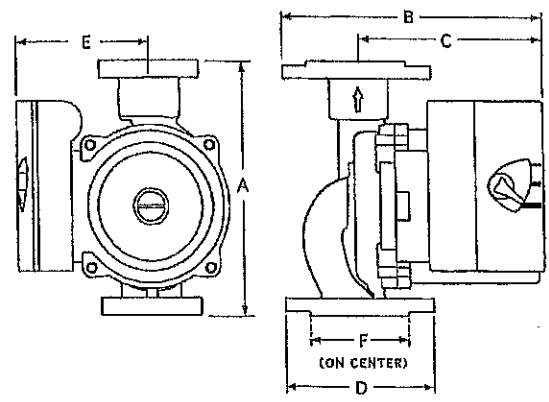

HARDWARE KIT

Companion flange kit (contains two (2) flanges, hardware and gaskets)

Cast iron: 0.75", 1", 1.25", 1.5"

Bronze: 0.75", 1", 1.25", 1.5"

Union fitting (contains two (2) half unions and gaskets)

1.25" NPSM to:

Brass/Lead free bronze: 0.5" sweat, 0.75" sweat, 0.75" FNPT

CHECK VALVE SIZE

CHECK VALVE SIZE	MODEL
1" Diameter	ASTRO 220SSU, ASTRO 225SSU
1¼" Diameter	ASTRO 210, ASTRO 230, ASTRO 250, ASTRO 280, ASTRO 286
1½" Diameter	ASTRO 290

CROUCH & SONS PLUMBING, LLC.

4438 Chisholm Rd, Florence, AL 35630

PH: 256-766-7770 FX: 256-766-0056

crouchandsonsplumbingllc@gmail.com

Subcontractor Warranty For Installation of 14 Gas Tankless Water Heaters

Regarding the installation of 14 tankless water heaters, for the Franklin County Commission, the following warranty will apply. A one year warranty on the Labor and Materials for the installation plumbing on 14 tankless water heaters. Crouch and Sons Plumbing llc, will provide all warranty information for supplied tankless water heaters. Navien Inc. provides a standard 8 year limited warranty on heat exchangers inside the tankless water heaters, and a 5 year limited warranty on parts. Any tampering with: valves, tankless water heater settings, and or venting/exhaust may lead to a loss of warranty from both Navien Inc. and Crouch and Sons Plumbing, llc.

Subcontractor(Crouch and Sons Plumbing):

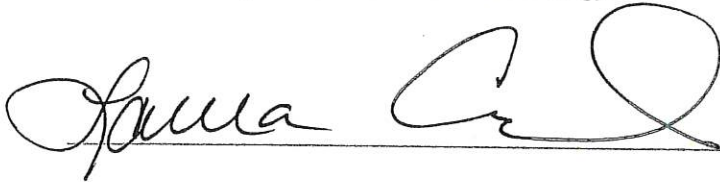
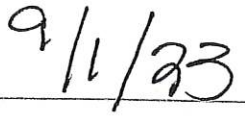

CROU&SO-01

JGILCHRIST

CERTIFICATE OF LIABILITY INSURANCE

DATE (MM/DD/YYYY)

8/29/2023

THIS CERTIFICATE IS ISSUED AS A MATTER OF INFORMATION ONLY AND CONFERS NO RIGHTS UPON THE CERTIFICATE HOLDER. THIS CERTIFICATE DOES NOT AFFIRMATIVELY OR NEGATIVELY AMEND, EXTEND OR ALTER THE COVERAGE AFFORDED BY THE POLICIES BELOW. THIS CERTIFICATE OF INSURANCE DOES NOT CONSTITUTE A CONTRACT BETWEEN THE ISSUING INSURER(S), AUTHORIZED REPRESENTATIVE OR PRODUCER, AND THE CERTIFICATE HOLDER.

IMPORTANT: If the certificate holder is an ADDITIONAL INSURED, the policy(ies) must have ADDITIONAL INSURED provisions or be endorsed. If SUBROGATION IS WAIVED, subject to the terms and conditions of the policy, certain policies may require an endorsement. A statement on this certificate does not confer rights to the certificate holder in lieu of such endorsement(s).

PRODUCER HJL/Florence P.O. Drawer F Florence, AL 35631		CONTACT NAME: Jerri Gilchrist PHONE (A/C, No, Ext): (256) 764-8682 FAX (A/C, No): (866) 597-2203 E-MAIL ADDRESS: jerrig@hjlinsurance.com	
INSURED Crouch & Sons Plumbing, LLC 4438 Chisholm Rd Florence, AL 35630		INSURER(S) AFFORDING COVERAGE	
		INSURER A: Auto Owners/Owners Ins Co.	NAIC # 18988
		INSURER B: AL Home Builders Self Ins Fund	NAIC # 52412
		INSURER C: Safety National Casualty Corp.	NAIC # 15105
		INSURER D:	
		INSURER E:	
		INSURER F:	

COVERAGES

CERTIFICATE NUMBER:

REVISION NUMBER:

THIS IS TO CERTIFY THAT THE POLICIES OF INSURANCE LISTED BELOW HAVE BEEN ISSUED TO THE INSURED NAMED ABOVE FOR THE POLICY PERIOD INDICATED. NOTWITHSTANDING ANY REQUIREMENT, TERM OR CONDITION OF ANY CONTRACT OR OTHER DOCUMENT WITH RESPECT TO WHICH THIS CERTIFICATE MAY BE ISSUED OR MAY PERTAIN, THE INSURANCE AFFORDED BY THE POLICIES DESCRIBED HEREIN IS SUBJECT TO ALL THE TERMS, EXCLUSIONS AND CONDITIONS OF SUCH POLICIES. LIMITS SHOWN MAY HAVE BEEN REDUCED BY PAID CLAIMS.

INSR LTR	TYPE OF INSURANCE	ADDL INSD	SUBR WVD	POLICY NUMBER	POLICY EFF (MM/DD/YYYY)	POLICY EXP (MM/DD/YYYY)	LIMITS
A	<input checked="" type="checkbox"/> COMMERCIAL GENERAL LIABILITY <input type="checkbox"/> CLAIMS-MADE <input checked="" type="checkbox"/> OCCUR GEN'L AGGREGATE LIMIT APPLIES PER: <input checked="" type="checkbox"/> POLICY <input type="checkbox"/> PRO-JECT <input type="checkbox"/> LOC OTHER: General Aggregate			38103261	1/1/2023	1/1/2024	EACH OCCURRENCE \$ 1,000,000 DAMAGE TO RENTED PREMISES (EA occurrence) \$ 300,000 MED EXP (Any one person) \$ 10,000 PERSONAL & ADV INJURY \$ 1,000,000 GENERAL AGGREGATE \$ 2,000,000 PRODUCTS - COMP/OP AGG \$ 2,000,000
A	<input checked="" type="checkbox"/> AUTOMOBILE LIABILITY <input checked="" type="checkbox"/> ANY AUTO OWNED AUTOS ONLY <input type="checkbox"/> SCHEDULED AUTOS <input type="checkbox"/> HIRED AUTOS ONLY <input type="checkbox"/> NON-OWNED AUTOS ONLY			4435504102	1/1/2023	1/1/2024	COMBINED SINGLE LIMIT (EA accident) \$ 1,000,000 BODILY INJURY (Per person) \$ BODILY INJURY (Per accident) \$ PROPERTY DAMAGE (Per accident) \$
	<input type="checkbox"/> UMBRELLA LIAB <input type="checkbox"/> OCCUR <input type="checkbox"/> EXCESS LIAB <input type="checkbox"/> CLAIMS-MADE DED RETENTION \$						EACH OCCURRENCE \$ AGGREGATE \$
B	WORKERS COMPENSATION AND EMPLOYERS' LIABILITY ANY PROPRIETOR/PARTNER/EXECUTIVE OFFICER/MEMBER EXCLUDED? (Mandatory in NH) <input type="checkbox"/> Y/N <input checked="" type="checkbox"/> Y If yes, describe under DESCRIPTION OF OPERATIONS below		N/A	20369	1/1/2023	1/1/2024	<input checked="" type="checkbox"/> PER STATUTE <input type="checkbox"/> OTH-ER E.L. EACH ACCIDENT \$ 1,000,000 E.L. DISEASE - EA EMPLOYEE \$ 1,000,000 E.L. DISEASE - POLICY LIMIT \$ 1,000,000
C	REINSURANCE			SP4067497	1/1/2023	1/1/2024	Included
A	Equipment Rental			38103261	1/1/2023	1/1/2024	50,000

DESCRIPTION OF OPERATIONS / LOCATIONS / VEHICLES (ACORD 101, Additional Remarks Schedule, may be attached if more space is required)

** Workers Comp information **

Proprietors/Partners/Executive Officers/Members Excluded: Anthony Crouch, Owner and Laura Crouch, Owner
Coverage for Workers' Compensation is limited to the provisions of the Alabama Workers' Compensation Law.

CERTIFICATE HOLDER

CANCELLATION

Franklin County Commission
405 Jackson Ave N.
Russellville, AL 35663

SHOULD ANY OF THE ABOVE DESCRIBED POLICIES BE CANCELLED BEFORE THE EXPIRATION DATE THEREOF, NOTICE WILL BE DELIVERED IN ACCORDANCE WITH THE POLICY PROVISIONS.

AUTHORIZED REPRESENTATIVE

2023

2023

Mailing Name and Address:

CROUCH & SONS PLUMBING, LLC
4438 CHISHOLM RD

FLORENCE AL 35630

CROUCH & SONS PLUMBING, LLC
4438 CHISHOLM RD

FLORENCE AL 35630

THIS LICENSE EXPIRES :

12/2023

Taxpayer ID Number :

14215

Location Number :

1

Date License Issued :

01/19/2023

License Number :

2023-402

**Non-transferable
Non-refundable**

Code	Description
238220	CONTRACTORS - HVAC/PLUMBING

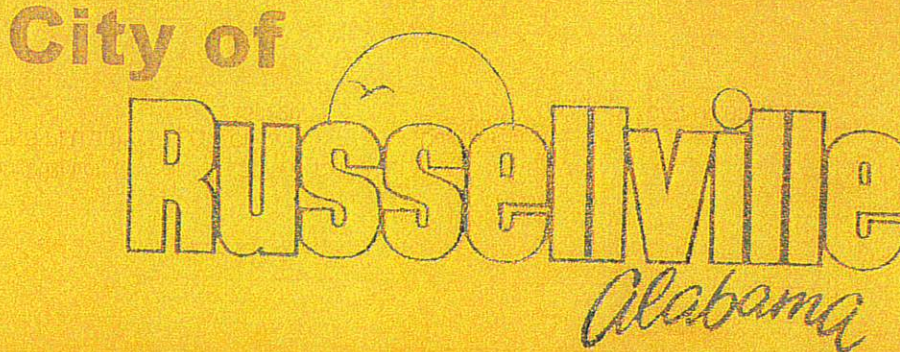

Issued By : Billy Fuller

Revenue Department

XX

Detach below prior to posting this business license

Business License Receipt	CITY OF RUSSELLVILLE, ALABAMA	SID:	01192023
CROUCH & SONS PLUMBING, LLC	Code 238220	Description CONTRACTORS - HVAC/PLUMBING	Amount \$80.00

Total Discount	\$0.00	Total License(s)	\$80.00
Total Fee 1-5	\$0.00	Total Penalty	\$0.00
Total Issue Fee	\$10.00	Total Interest	\$0.00
		Total Amount Remitted	\$90.00

STATE OF ALABAMA



State Licensing Board for General Contractors

BID LIMIT:

AMOUNT:

S- 55736

LICENSE NO.:

TYPE:

RENEWAL

THIS IS TO CERTIFY THAT

CROUCH & SONS PLUMBING, LLC
FLORENCE, AL 35630

is hereby licensed a General Contractor in the State of Alabama and is authorized to perform the following type(s) of work:

SUBCONTRACTOR: PLUMBING

until **October 31, 2023** when this Certificate expires.

Witness our hands and seal of the Board, dated Montgomery, Ala.,

25th day of October, 2022

Michael B. Lewis

SECRETARY-TREASURER

David A. Carter

CHAIRMAN

189326



Executive Director

ALABAMA PLUMBERS & GAS
FITTERS EXAMINING BOARD
216 AQUARIUS DRIVE
SUITE 319
HOMEWOOD, ALABAMA 35209
Phone: (205) 945-4857

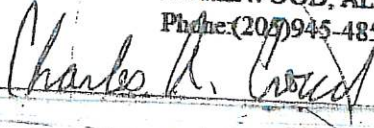

VALID THRU
December 31 2023

STATE OF ALABAMA
CERTIFIED
Master Plumber

CHARLES A CROUCH
151 CO RD 290
FLORENCE, AL 35634
MP-0409

2023

**SCHOOL RESORCE OFFICER AGREEMENT WITH FRANKLIN COUNTY
SCHOOLS**

It is on motion of Mr. Joseph Baldwin, second by Mr. David Hester unanimously ordered, adjudged and decreed by the Board to approve the school resource officer agreement with Franklin County Schools for Officer Baker.

Agreement as follows:

MEMORANDUM OF AGREEMENT
October 1, 2023 – September 30, 2024

A School Resource Officer Program will be established with the Franklin County Schools, the Franklin County Commission and the Franklin County Sheriff's Department.

The Franklin County Sheriff's Department shall provide one School Resource Officer for the Franklin County School System.

The Franklin County School System, the Franklin County Commission and the Franklin County Sheriff's Department will be responsible for the salary of \$32,000.00 for **Bobby Greg Baker** and divided as follows:

Franklin County Schools – \$16,000.00

Franklin County Commission - \$16,000.00

Franklin County Sheriff's Department – Gun, Ammunition, Taser, Car, Fuel, Benefit Package and Required Training.

The School Resource Officer will divide time equally among the schools in Franklin County, or per request of the Superintendent of Education as specifically assigned.

The School Resource Officer may not be called away from the school setting to address other law enforcement issues.

The School Resource Officer must complete SRO Training, NARSO approved. The School Resource Officer must have completed Active Shooter Training. The School Resource Officer shall not act as a disciplinarian.

The School Resource Officer shall become familiar with all Board of Education Policies and the Code of Student Conduct.

The School Resource Officer shall act as and be considered a school official for searches and seizures based on reasonable suspicion authorized by New Jersey vs. T.L.O.

The School Resource Officer shall take law enforcement action as required.

The use of confidential school records by the SRO shall be done as allowed under the Family Educational Rights and Privacy Act.

The Franklin County School System, The Franklin County Commission and the Franklin County Sheriff's Department agree to cooperate in good faith in fulfilling the terms of this agreement. Unforeseen difficulties will be resolved by negotiation between the Superintendent of Education and the Franklin County Sheriff.

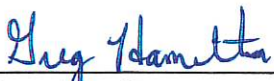

Greg Hamilton
Superintendent of Education



Shannon Oliver
Franklin County Sheriff



Barry Moore
Commission Chairman

**SCHOOL RESORCE OFFICER AGREEMENT WITH FRANKLIN COUNTY
SCHOOLS**

It is on motion of Mr. Jason Miller, second by Mr. Chris Wallace unanimously ordered, adjudged and decreed by the Board to approve the school resource officer agreement with Franklin County Schools for Officer Washington.

Agreement as follows:

MEMORANDUM OF AGREEMENT
October 1, 2023 – September 30, 2024

A School Resource Officer Program will be established with the Franklin County Schools, the Franklin County Commission and the Franklin County Sheriff's Department.

The Franklin County Sheriff's Department shall provide one School Resource Officer for the Franklin County School System.

The Franklin County School System, the Franklin County Commission and the Franklin County Sheriff's Department will be responsible for the salary of \$24,000.00 for **Sammie Washington** and divided as follows:

Franklin County Schools – \$24,000.00

Franklin County Sheriff's Department – Gun, Ammunition, Taser, Car, Fuel, Benefit Package and Required Training.

The School Resource Officer will divide time equally among the schools in Franklin County, or per request of the Superintendent of Education as specifically assigned.

The School Resource Officer may not be called away from the school setting to address other law enforcement issues.

The School Resource Officer must complete SRO Training, NARSO approved. The School Resource Officer must have completed Active Shooter Training. The School Resource Officer shall not act as a disciplinarian.

The School Resource Officer shall become familiar with all Board of Education Policies and the Code of Student Conduct.

The School Resource Officer shall act as and be considered a school official for searches and seizures based on reasonable suspicion authorized by New Jersey vs. T.L.O.

The School Resource Officer shall take law enforcement action as required.

The use of confidential school records by the SRO shall be done as allowed under the Family Educational Rights and Privacy Act.

The Franklin County School System, The Franklin County Commission and the Franklin County Sheriff's Department agree to cooperate in good faith in fulfilling the terms of this agreement. Unforeseen difficulties will be resolved by negotiation between the Superintendent of Education and the Franklin County Sheriff.



Greg Hamilton
Superintendent of Education



Shannon Oliver
Franklin County Sheriff



Barry Moore
Commission Chairman

**SCHOOL RESOURCE OFFICER AGREEMENT WITH FRANKLIN COUNTY
SCHOOLS**

It is on motion of Mr. Chris Wallace, second by Mr. David Hester unanimously ordered, adjudged and decreed by the Board to approve the school resource officer agreement with Franklin County Schools for Officer Cantrell.

Agreement as follows:

MEMORANDUM OF AGREEMENT
October 1, 2023 – September 30, 2024

A School Resource Officer Program will be established with the Franklin County Schools, the Franklin County Commission and the Franklin County Sheriff's Department.

The Franklin County Sheriff's Department shall provide one School Resource Officer for the Franklin County School System.

The Franklin County School System, the Franklin County Commission and the Franklin County Sheriff's Department will be responsible for the salary of \$56,418.86 for **Regina Cantrell** and divided as follows:

Franklin County Schools – \$56,418.86

Franklin County Sheriff's Department – Gun, Ammunition, Taser, Car, Fuel, Benefit Package and Required Training.

The School Resource Officer will divide time equally among the schools in Franklin County, or per request of the Superintendent of Education as specifically assigned.

The School Resource Officer may not be called away from the school setting to address other law enforcement issues.

The School Resource Officer must complete SRO Training, NARSO approved. The School Resource Officer must have completed Active Shooter Training. The School Resource Officer shall not act as a disciplinarian.

The School Resource Officer shall become familiar with all Board of Education Policies and the Code of Student Conduct.

The School Resource Officer shall act as and be considered a school official for searches and seizures based on reasonable suspicion authorized by New Jersey vs. T.L.O.

The School Resource Officer shall take law enforcement action as required.

The use of confidential school records by the SRO shall be done as allowed under the Family Educational Rights and Privacy Act.

The Franklin County School System, The Franklin County Commission and the Franklin County Sheriff's Department agree to cooperate in good faith in fulfilling the terms of this agreement. Unforeseen difficulties will be resolved by negotiation between the Superintendent of Education and the Franklin County Sheriff.



Greg Hamilton
Superintendent of Education



Shannon Oliver
Franklin County Sheriff



Barry Moore
Commission Chairman

PROMOTION

It is on motion of Mr. Chris Wallace, second by Mr. David Hester unanimously ordered, adjudged and decreed by the Board to approve the promotion of Bretta Wigginton to Lieutenant effective September 17, 2023.

Letter as follows:



SHANNON OLIVER
SHERIFF

FRANKLIN COUNTY SHERIFF'S OFFICE

748 WALNUT GATE ROAD
RUSSELLVILLE, ALABAMA 35654

OFFICE 256-332-8811

JAIL 256-332-8425

FAX 256-332-8816

September 8, 2023

Barry Moore, Chairman
Franklin County Commission
PO Box 1028
Russellville, AL 35653

Gentlemen,

I am promoting Bretta Wigginton to Lieutenant. Effective September 17, 2023.

Sincerely,

A handwritten signature in black ink, appearing to be "S.O.", written over the printed name.

Shannon Oliver
Sheriff

SOLID WASTE

HIRE PERMANENT HEAVY EQUIPMENT OPERATOR

It is on motion of Mr. Joseph Baldwin, second by Mr. Chris Wallace unanimously ordered, adjudged and decreed by the Board to approve the hiring of Lee Bryant effective September 5, 2023.

Letter as follows:



FRANKLIN COUNTY SOLID WASTE

P.O. Box 1205
RUSSELLVILLE, ALABAMA 35653



PHONE (256) 332-8412
FAX (256) 332-8855



September 11, 2023

Judge Barry Moore
Commission Chairman
Franklin County Commissioners
P.O.Box 1028
Russellville, AL 35653

Re: Heavy Equipment Operator

Gentleman,

We are requesting to hire Lee Bryant as a full-time employee as Heavy Equipment Operator as of 09/05/2023.

Thank you,

Robert Ward
Landfill Manager
Franklin County Solid Waste
(256) 332-8412

HIRE TEMPORARY HEAVY EQUIPMENT OPERATOR

It is on motion of Mr. Chris Wallace, second by Mr. David Hester unanimously ordered, adjudged and decreed by the Board to approve the hiring of temporary Heavy Equipment Operator Jeff Dill effective October 2, 2023.

Letter as follows:



FRANKLIN COUNTY SOLID WASTE

P.O. Box 1205
RUSSELLVILLE, ALABAMA 35653



PHONE (256) 332-8412
FAX (256) 332-8855



September 11, 2023

Judge Barry Moore
Commission Chairman
Franklin County Commissioners
P.O.Box 1028
Russellville, AL 35653

Re: Heavy Equipment Operator

Gentleman,

We are requesting to hire Jeff Dill as a temporary Heavy Equipment Operator as of 10/02/2023.

Thank you,

Robert Ward
Landfill Manager
Franklin County Solid Waste
(256) 332-8412

TERMINATION OF HEAVY EQUIPMENT OPERATOR

It is on motion of Mr. David Hester, second by Mr. Chris Wallace unanimously ordered, adjudged and decreed by the Board to approve the termination of Heavy Equipment Operator Lee Bryant effective September 13, 2023.

ADVERTISE FOR HEAVY EQUIPMENT OPERATOR

It is on motion of Mr. Joseph Baldwin, second by Mr. Jason Miller, unanimously ordered, adjudged and decreed by the Board to approve the advertisement of Heavy Equipment Operator.

Letter as follows:



FRANKLIN COUNTY SOLID WASTE

P.O. Box 1205
RUSSELLVILLE, ALABAMA 35653



PHONE (256) 332-8412
FAX (256) 332-8855



September 13, 2023

Judge Barry Moore
Commission Chairman
Franklin County Commissioners
P.O. Box 1028
Russellville, AL 35653

Re: Heavy Equipment Operator

Gentleman,

We are requesting to terminate Lee Bryant from Heavy Equipment Operator as of 09/13/2023.

We are now requesting to advertise for Heavy Equipment Operator.

Thank you,

Robert Ward
Landfill Manager
Franklin County Solid Waste
(256) 332-8412

UPDATE PAY SCALES, JOB DESCRIPTIONS, AND PERSONNEL POLICIES

It is on motion of Mr. Chris Wallace, second by Mr. Jason Miller, unanimously ordered, adjudged and decreed by the Board to approve the quote with UNA for \$25,000 updating the pay scales, job descriptions, and personnel policies.

Quote as follows:

Proposal for Franklin County Employee Study
Institute for Innovation and Economic Development
University of North Alabama

The following is a proposal for the study as discussed. Please let us know if you need anything further.

The work plan for each deliverable is as follows:

PART I: Job Description Development & Compensation Plan

- Develop a communications plan for the compensation project
- Perform job analysis/evaluation for each classification
- Prepare job descriptions
- Conduct wage and salary analyses relative to appropriate comparators
- Validate classifications within current structure and suggest adjustments as needed
- Communicate results and develop implementation strategies for Compensation Plan
- Provide ongoing support/consultation

PART II: Employee Handbook Revision

- Examine current employee handbook and assess status of various policies
- Revise existing policies and suggest policy additions to reflect current employment laws and industry best practices
- Present draft version to appropriate parties for review/suggested revisions
- Present final version of handbook in desired versions

PART I: JOB DESCRIPTION DEVELOPMENT & COMPENSATION PLAN

Develop a communications plan for the compensation project

Work with Franklin County Commission stakeholders to receive input regarding current salary structure including challenges and budget. Develop a timeline for milestones and final report. In consultation with Franklin County Project Manager, develop a communication plan for the various milestones.

Communication plan components may include kickoff presentation, proposed email or newsletter content for announcements and updates, and a specialized plan for final report presentation and individual compensation notifications.

Perform Job Analysis/Evaluation for Each Classification

Perform a comprehensive job analysis/evaluation of each position utilizing various methods to include analysis of current position descriptions and those of relevant comparators, the Job Content Questionnaire (JCQ), and incumbent interviews as necessary. Immediate supervisor input for each classification should also be included.

The Job Content Questionnaire (JCQ) is designed to collect data regarding regularly-performed job duties and responsibilities as well as data for factors such as required education level, required experience, financial authority, job complexity, physical demands, and work environment. The JCQ presents information in an easily-understandable format and can be completed by each incumbent.

Prepare job descriptions

Review and examine questionnaires, interview notes, and any additional information to develop a draft job description for each position/classification. All job descriptions will be developed in Microsoft Word format and will include factors such as:

- Minimum qualifications
- Essential job functions
- Materials/equipment used
- Special certifications or requirements
- Characteristics of the position (physical, environmental, and sensory), compliant with ADA
- Suggested FLSA status of the position (UNA consultants are not attorneys and do not provide legal advice)

Design new job description format. Provide draft job descriptions to the Franklin County Project Manager in Microsoft Word for review and suggested revisions. Make appropriate revisions, prepare final versions, and provide to Franklin County Project Manager as both Microsoft Word and PDF files.

Conduct wage and salary analyses relative to appropriate market

Obtain the existing pay structure and compensation philosophy. Request and verify detailed data on each employee (preferably in Excel): unique identifier, salary, age, years of service, current rank/title, years in current rank/title, current classification, department,

race, ethnicity, and gender. Analyze data and work with Franklin County Project Manager to understand the organizational structure and current compensation structure and practices.

Gather relevant wage and salary market data using provided ACCA Wage and Salary Survey as well as Department of Labor and Bureau of Labor Statistics data to assess external market competitiveness.

Validate classifications within current structure and suggest adjustments as needed

Use new job analyses and resulting job descriptions to determine appropriate salary levels for each incumbent based on market data. UNA consultants will advise if the current pay grade levels are appropriately assigned for all incumbents and/or will make recommendations for new grade level assignments. The goals are to ensure that recommended pay structures possess both internal and external equity and are inherently non-discriminatory.

Communicate results and develop implementation strategies

Provide Franklin County Project Manager with comprehensive reports to include project methodologies, market analysis information, recommended adjustments, anticipated costs, options/recommendations for implementation, and other reports helpful for the overall understanding of the results, implementation, and continued maintenance of the plan.

Develop an updated compensation plan that is based on the results of the competitive market analysis and reflects current job evaluations, is efficient to manage, and contributes to the overall efficiency and effectiveness of operation. Provide suggested guidelines to maintain the integrity of the new classification plan. Prepare/update policies and procedures for plan maintenance.

Present final plan to Franklin County Commission officials at a designated time. Prepare communication plan for affected employees. Train appropriate staff in the job the administration of the pay structure.

Provide ongoing support/consultation

Provide consultation to Franklin County Project Manager for a period of 12 months regarding maintenance of the plan including follow-up with key stakeholders to address any issues related to system implementation.

PART II: EMPLOYEE HANDBOOK

Examine current employee handbook and assess status of various policies

UNA consultant will initially meet with appropriate Franklin County Commission staff to discuss the current employee handbook, including issues, concerns, and desired outcomes. Consultant will obtain all pertinent documents for review and revision.

Revise existing policies and suggest policy additions to reflect current employment laws and industry best practices

UNA consultant will revise existing policies to reflect best practices and will recommend needed policies to ensure legal compliance with current regulations, legislation, and industry best practices. Consultant will streamline the resulting employee handbook so that it is an easy-to-use guide for both employees and management while ensuring the desired professional outcomes and appropriate policy language are incorporated to provide a best practice product that also reflects compliance with current employment laws.

Present draft version to appropriate parties for review/suggested revisions

UNA Consultant will provide a draft revision of the new employee handbook for review in digital "track changes" format to appropriate Franklin County Commission officials. Franklin County Commission officials will provide feedback as needed within the digital version or in a scanned document to be shared with UNA consultant.

Present final version of handbook in desired versions

UNA Consultant will incorporate any suggested changes from Franklin County Commission officials and will and prepare a final version for delivery to appropriate officials. Available formats are Microsoft Word, Google Doc, Adobe PDF, and/or a web-based product.

The final report will be delivered by December 4, 2023. Payment will be due upon receipt of the final report. The following is a breakdown of the total cost of the project.

Project Cost:

UNA Consultant compensation:	\$21,000
<u>Institute (covers expenses):</u>	<u>4,000</u>
Total Project:	\$25,000

FY24 MEETING SCHEDULE

It is on motion of Mr. David Hester, second by Mr. Chris Wallace, unanimously ordered, adjudged and decreed by the Board to approve the Meeting Schedule for FY23-24.

Commissioner Jason Miller abstained from voting.

FY23-24 Meeting Schedule as follows:

**Franklin County Commission
FY2023-2024 Meeting Schedule**

<u>Date</u>	<u>Type</u>	<u>Time</u>
October 10, 2023*	Work Session	5:00 PM
October 16, 2023	Regular Meeting	8:30 AM
November 13, 2023	Work Session	5:00 PM
November 20, 2023	Regular Meeting	8:30 AM
December 11, 2023	Work Session	5:00 PM
December 18, 2023	Regular Meeting	8:30 AM
January 8, 2024	Work Session	5:00 PM
January 16, 2024*	Regular Meeting	8:30 AM
February 12, 2024	Work Session	5:00 PM
February 20, 2024*	Regular Meeting	8:30 AM
March 11, 2024	Work Session	5:00 PM
March 18, 2024	Regular Meeting	8:30 AM
April 8, 2024	Work Session	5:00 PM
April 15, 2024	Regular Meeting	8:30 AM
May 13, 2024	Work Session	5:00 PM
May 20, 2024	Regular Meeting	8:30 AM
June 10, 2024	Work Session	5:00 PM
June 17, 2024	Regular Meeting	8:30 AM
July 8, 2024	Work Session	5:00 PM
July 15, 2024	Regular Meeting	8:30 AM
August 12, 2024	Work Session	5:00 PM
August 19, 2024	Regular Meeting	8:30 AM
September 9, 2024	Work Session	5:00 PM
September 16, 2024	Regular Meeting	8:30 AM

*Denotes meeting fell on a Holiday and was rescheduled.

2024 HOLIDAY SCHEDULE

It is on motion of Mr. Jason Miller, second by Mr. Chris Wallace, unanimously ordered, adjudged and decreed by the Board to approve the 2024 Holiday Schedule.

2024 Holiday Schedule as follows:

STATE OF ALABAMA

FRANKLIN COUNTY

RESOLUTION

WHEREAS, the official Holiday Schedule has been received from the Governor's Office in which the days listed below have been declared for observance during the 2024 holiday season.

HOLIDAYS 2024

January 1	New Year's Day
January 15	R. E. Lee/M.L. King Birthday
February 19	Washington/Jefferson Birthday
April 22	Confederate Memorial Day
May 27	Memorial Day
June 3	Jefferson Davis' Birthday
July 4	Independence Day
September 2	Labor Day
October 14	Columbus Day
November 11	Veterans' Day
November 28	Thanksgiving
December 25	Christmas

All employees who have satisfactorily completed a six-month probationary period are entitled to one floating holiday during the calendar year, to be taken at the discretion of the supervisor.

NOW THEREFORE BE IT FURTHER RESOLVED by the Franklin County Commission that the designated holidays for observance in the calendar year 2024 shall be those designated by the State of Alabama, Office of the Governor declared with at least a 48-hour notice.

Done this the 18th day of September, 2023.

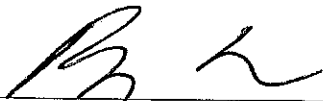

Chairman, Franklin County Commission



STATE OF ALABAMA

2024

OFFICIAL STATE HOLIDAYS

Monday, January 1	New Year's Day
Monday, January 15	Martin Luther King, Jr & Robert E. Lee's Birthday
Tuesday, February 13	Mardi Gras*
Monday, February 19	George Washington & Thomas Jefferson's Birthday
Monday, April 22	Confederate Memorial Day
Monday, May 27	National Memorial Day
Monday, June 3	Jefferson Davis' Birthday
Thursday, July 4	Fourth day of July
Monday, September 2	Labor Day
Monday, October 14	Columbus Day & Fraternal Day & American Indian Heritage Day
Monday, November 11	Veterans' Day
Thursday, November 28	Thanksgiving**
Sunday, December 1	Mrs. Rosa L. Parks Day*** <i>(Commemoration Only)</i>
Wednesday, December 25	Christmas Day

* Mardi Gras is observed only in Baldwin and Mobile Counties. All other State Employees are granted one personal leave day each year if in employment status on January 1.

** Upon designation by the Governor.

*** December 1 of each year is designated as Mrs. Rosa L Parks Day to commemorate her accomplishments. Each resident of this state is requested to observe the day with appropriate activities.

Note: Holidays that fall on Sunday are observed on Monday; holidays that fall on Saturday are observed on Friday.

FY23 FINANCIAL STATEMENT

It is on motion of Mr. Joseph Baldwin, second by Mr. Chris Wallace, unanimously ordered, adjudged and decreed by the Board to approve the FY23 financial statement.

FY24 CHAMBER OF COMMERCE CONTRACT

It is on motion of Mr. Chris Wallace, second by Mr. Jason Miller, unanimously ordered, adjudged and decreed by the Board to approve the FY24 Chamber of Commerce Contract for \$6,600 with 10% increase over the next 2 years.

Contract as follows:



Contract for Services

October 2023 – September 2024

Franklin County Commission
Russellville, Alabama

The Franklin County Chamber of Commerce, in the performance of its operations and contract agreement with the Franklin County Commission, agrees to contract with the Franklin County Commission for services hereinafter set forth.

- I. The Chamber is the Welcome Center for information, maps, newcomers, membership directories and tourism brochures.
- II. The Chamber assists in coordinating ground breakings, grand openings, ribbon cuttings, civic presentations and other activities involving the city and its officials.
- III. The Chamber counsels and assists potential new and expanding businesses, agri-business, industry agencies, institutions and people relocating to the area.
- IV. The Chamber will utilize social media to the greatest extent possible to promote Franklin County events.
- V. The Chamber will design and make available for purchase souvenir postcards to promote Franklin County.
- VI. The Chamber will have a direct link from the Chamber's website to the Franklin County's website.
- VII. Through the management and staff of the Chamber, to do everything possible as funding permits, to foster and promote Franklin County and to create and maintain its good name and good will.

The Franklin County Chamber of Commerce requests an appropriation from the Franklin County Commission from October 2023 until September 2024, to enable the Chamber to develop and promote the interest of Franklin County and its businesses.

Appropriation granted in the amount of \$6,600.00 per year or \$1,650.00 per quarter for four quarters on this the 15th day of September 2023. Appropriations will increase 10% for the next two fiscal years.

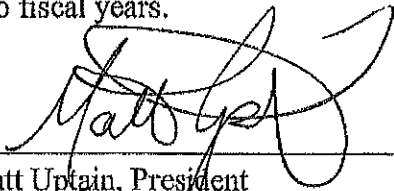
Matt Uptain, President
Franklin County Chamber of Commerce
Board of Directors

Barry Moore, Probate Judge
Franklin County, Alabama

FY24 DISTRICT ATTORNEY CONTRACT

It is on motion of Mr. Joseph Baldwin, second by Mr. David Hester, unanimously ordered, adjudged and decreed by the Board to approve the FY24 District Attorney Contract.

Contract as follows:

STATE OF ALABAMA

FRANKLIN COUNTY

AGREEMENT

Come now the State of Alabama, Office of the District Attorney, 34th Judicial Circuit, hereinafter referred to as "District Attorney" and the Franklin County Commission, and enter into the following agreement based upon the mutual promises and consideration herein:

1. The District Attorney agrees to pay to the Franklin County Commission \$600.00 per year as an administrative fee for keeping the books for the District Attorney's Worthless Check Unit.
2. The Franklin County Commission agrees to keep the books for the District Attorney's Worthless Check Unit and to waive the arrest fee to the District Attorney to defray the expense of the Worthless Check Program.
3. Effective October 1, 2023, through September 30, 2024.

WHEREFORE, IN CONSIDERATION OF THE MUTUAL PROMISES MADE
HEREIN, we do hereunto set our hands and seals on 18th day of September, 2023.

District Attorney
34th Judicial Circuit



Chairman, Franklin County Commission

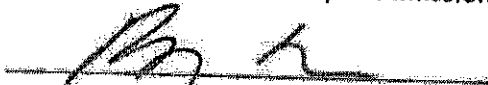

FY24 COMMUNITY CORRECTIONS CONTRACT

It is on motion of Mr. David Hester, second by Mr. Chris Wallace, unanimously ordered, adjudged and decreed by the Board to approve the FY24 Community Corrections Contract.

Contract as follows:

FRANKLIN COUNTY

CONTRACT

This Agreement, made this the 18th day of September, 2023,
between Franklin County Commission, hereinafter referred to as "Commission" and
Franklin County Community Corrections, Inc., a Community Punishment and Corrections
Authority of the 34th Judicial Circuit, hereinafter referred to as "FCCC, Inc."

WITNESSETH

The Commission and FCCC, Inc. agree as follows:

ARTICLE I:

The Commission will provide services to FCCC, Inc., to include three (3) full-time employees. Additional employees may be hired with a maximum number of six (6) employees. These employees will be treated as employees of the Franklin County Commission for payroll purposes only. This agreement will be modified upon the addition of each employee to reflect reimbursement of the salaries and benefits of the employees hired. FCCC, Inc. acknowledges that the employees will be available only so long as FCCC, Inc. reimburses the County for the expenses associated with such employees. It is expressly agreed and understood that any employees hired by the Franklin County Commission under the FCCC, Inc. grant acknowledges and understands that they will be terminated upon the end of the grant funding and that they have not obtained a permanent position with the Franklin County Commission as an employee. In the event that this contract is terminated for any reason, any accumulated annual leave/sick leave/benefits shall be the responsibility of FCCC, Inc.

Additionally, the Commission agrees to provide office space sufficient for the employees assigned to FCCC, Inc. Said offices shall be located at the Franklin County Courthouse. FCCC, Inc. agrees to pay \$1.00 per year as their share of rent and utilities and other good and valuable consideration for the use of said space.

ARTICLE II:

The term of the Contract shall be for a period of one (1) year commencing on October 1, 2023. At the expiration of the initial term hereof, FCCC, Inc. has complied with all the terms and conditions hereof, this Contract is subject to renewal for an additional term of one (1) year on the same terms and conditions contained herein, excluding the yearly consideration and/or monthly installment amount, which shall be re-negotiated at that time. Either party hereto can terminate this contract during the initial term hereunder by giving the other party thirty (30) days written notice to terminate by certified mail, return receipt requested.

ARTICLE III:

FCCC, Inc. will pay to Commission a sum as determined by the parties per year for the services referred to in ARTICLE I above which shall be adjusted upon additional employees being hired. Said sum shall be payable in quarterly installments with the first quarterly installment due and payable on or before the 31st day of January, 2024, and a like sum on the same day each quarter for the term(s) set forth herein. Quarterly payment adjustments will be made with the hiring of additional employees.

ARTICLE IV:

Both parties will strive to provide good service to the people of Franklin County, Alabama; however, both parties agree that the Commission shall not be liable for any actions or lack thereof by FCCC, Inc. FCCC, Inc. will keep in effect and provide proof of an insurance policy for coverage of their action and furthermore agrees to hold the Franklin County Commission harmless for any action or inaction taken by the FCCC, Inc. in its official capacity.

IN WITNESS WHEREOF, the parties have hereunto set their hands and seals the day and date above written.

WITNESSES:

Leah Mansell

FRANKLIN COUNTY COMMISSION:

BY: 
It's Chairman

FRANKLIN COUNTY COMMUNITY
CORRECTIONS, INC.

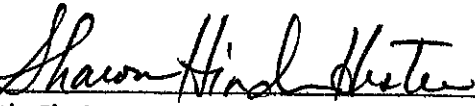
BY: 
It's Chairman

FY24 COMMUNITY MENTAL HEALTH OFFICER CONTRACT

It is on motion of Mr. David Hester, second by Mr. Jason Miller, unanimously ordered, adjudged and decreed by the Board to approve the FY24 Community Mental Health Officer Contract.

Contract as follows:

September 18, 2023

I, Probate Judge Barry Moore, enter into a contractual agreement with Sheriff Shannon Oliver for Mental Health Officer services as done by **Colt Montgomery, Chase White and Kyle Palmer** for Franklin County. This contract is effective from October 1, 2023 until September 30, 2024. The \$7500 fee will be deposited into the overtime line item in the Sheriff's Office budget.

Sincerely,

A handwritten signature in black ink, appearing to be 'BM', written in a cursive style.

Barry Moore, Probate Judge and Chairman
Franklin County Commission

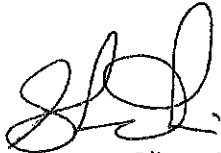
A handwritten signature in black ink, appearing to be 'S.O.', written in a cursive style.

Shannon Oliver, Sheriff
Franklin County

SALES TAX AUDITING AND COLLECTION SERVICES CONTRACT

It is on motion of Mr. Joseph Baldwin, second by Mr. David Hester, unanimously ordered, adjudged and decreed by the Board to approve the sales tax auditing and collection services contract.

Contract as follows:

STATE OF ALABAMA)
FRANKLIN COUNTY)

TAX SERVICE CONTRACT

This Agreement made and entered into on this the 18th day of September 2023 by and between the Franklin County, Alabama Commission, hereinafter referred to as COUNTY and Sales Tax Auditing & Collection Services, hereinafter referred to as STACS.

WITNESSETH

WHEREAS, COUNTY is desirous of contracting with an entity for the purpose of handling the collection of its sales, use, and other taxes; and performing revenue examination services (auditing) and;

WHEREAS, STACS has offered its services as an independent contractor for the purpose of performing these services; and,

WHEREAS, the parties hereto are desirous of memorializing their agreement concerning the services to be provided by STACS and the consideration to be paid by COUNTY for said services.

NOW THEREFORE, for and in consideration of the mutual promises and covenants herein made and of the acts to be performed by the parties hereto, it is mutually agreed and each covenant and agrees as follows:

- 1) COUNTY will provide to STACS an updated copy of all ordinances, resolutions and agreements related to sales, use, and other taxes.
- 2) STACS will perform the following tax collection services:
 - a) STACS will notify taxpayers and prepare and mail forms and other documentation necessary to collect, document taxpayer payments and remit tax revenues to COUNTY.
 - b) Upon receipt of taxpayer remittance forms and tax payments, STACS will verify the accuracy of the taxpayers' tax calculations and record the amounts submitted for payment.
 - c) STACS will deposit tax monies in COUNTY'S bank account(s) generally on the same day of receipt but always within twenty-four (24) hours of receipt by STACS.
 - d) STACS will mail notices to taxpayers relating to delinquencies, under and over payments, and bad checks.
 - e) Each month STACS will provide COUNTY detailed and summary reports of tax collection activities.
- 3) STACS will perform the following revenue examination (auditing) services for COUNTY:
 - a) Identify candidates for audit and provide information for COUNTY to use to determine if an audit is appropriate. STACS will not initiate a local audit without prior approval by COUNTY.
 - b) When conducting audits initiated by other STACS clients, STACS will include COUNTY on the required list of entities for which the examination is being conducted. (as required by the Alabama Taxpayers' Bill of Rights)
 - c) Perform examinations of taxpayer records in accordance with the "Minimum Standard Examination Program" established by the Alabama Local Tax Institute of Standard and Training.
 - d) Present to COUNTY a monthly "Audit Findings Report" if applicable.

- e) Assist in the preparation of any legal documents that may be required to collect any amounts due from the taxpayer. (Note also that examiners are required by law to notify the taxpayer if any tax overpayments are discovered and the taxpayer is due any refunds.)
- 4) COUNTY will pay the following:
 - a) For sales and use tax collection services, the sum of ONE THOUSAND SEVEN HUNDRED FIFTY AND 00/100 (\$1,750.00) DOLLARS per month. STACS will bill COUNTY for services rendered pursuant to the consideration referred to in this paragraph on or before the tenth (10th) day of the month following the tax month for which tax payment is due and COUNTY shall pay STACS by the thirtieth (30th) day of the month in which STACS bills COUNTY.
 - b) For revenue examination (auditing) services, the sum of SEVENTY-FIVE and 00/100 (\$75.00) per hour. If overnight travel outside the State of Alabama is required, STACS will obtain prior written approval from COUNTY and STACS will be paid an agreed upon travel expense and daily per-diem amount. It is understood that each STACS client will only pay a prorated portion of audit fees when STACS is conducting audits for multiple clients at one time. Both parties, to this agreement, understand that State of Alabama legislation specifically prohibits any form of auditing on a contingency fee basis and further agree that STACS compensation is not, in any way, connected to the amounts discovered during audits nor connected to amounts finally received by COUNTY.
- 5) This Contract shall be for a term of three (3) years beginning October 1, 2023 and expiring September 30, 2026.
- 6) This Agreement constitutes the entire agreement between the parties hereto and supersedes any prior understandings or written or oral agreements between the parties respecting the subject matter contained herein. Said Agreement shall not be amended, altered, or changed, except by a written Agreement signed by both of the parties hereto.

IN WITNESS WHEREOF, this Agreement has been executed by the parties on this the 18th day of September 2023.

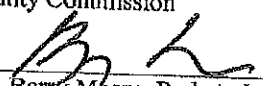
Franklin County Commission
 BY: 
 Barry Moore, Probate Judge

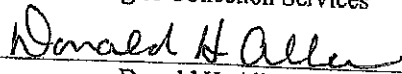
Sales Tax Auditing & Collection Services
 BY: 
 Donald H. Allen

Title: CHAIRMAN
 ATTEST: 
 Leah Mansell, County Administrator

Title: OWNER

NACOLG BOARD APPOINTMENTS

It is on motion of Mr. Jason Miller, second by Mr. David Hester, unanimously ordered, adjudged and decreed by the Board to re-appoint Jerry Groce to the NACOLG Board of Directors.

Letter as follows:

Jerry W. & Benetia Groce
740 Hamilton Street
Russellville, AL 35653
jgroce6997@bellsouth.net

September 11, 2023

Hon. Barry Moore, Probate Judge
Franklin County Commission
405 N. Jackson Avenue
P.O. Box 1028
Russellville, AL 35653

Dear Judge Moore
Franklin County Commissioners,

It is a great honor for me to currently serve as the Franklin County representative to the Board of Directors for the Northwest Alabama Council of Local Governments (NACOLG). I am writing to request reappointment to this position. In addition to serving with a great group of people, I have an opportunity to be an advocate for services and programs that will benefit the residents of Franklin County. If reappointed I will continue to work hard to serve in a manner that will bring honor to the County Commission and Franklin County. I appreciate your consideration and feel free to contact me if additional information is needed.

Sincerely,

Jerry W. Groce
(256) 577-7214

Cc: County Commissioners

NACOLG BOARD APPOINTMENTS

It is on motion of Mr. Joseph Baldwin, second by Mr. David Hester, unanimously ordered, adjudged and decreed by the Board to re-appoint Brente Jeffreys to the NACOLG Board of Directors.

Letter as follows:

Leah Mansell

From: Brente Jeffreys <brentejeffreys@gmail.com>
Sent: Friday, September 8, 2023 8:46 AM
To: Leah Mansell
Subject: Reappointment to NACOLG Board

I am requesting reappointment to the NACOLG Board representing Franklin County.

Thank you for your consideration.

Best regards,

Brente Jeffreys

Sent from my iPhone=

NACOLG BOARD APPOINTMENTS

It is on motion of Mr. David Hester, second by Mr. Jason Miller, unanimously ordered, adjudged and decreed by the Board to re-appoint Lavon Duboise to the NACOLG Board of Directors.

Letter as follows:

September 8, 2023

Franklin County Commission

Commission Office

Russellville, AL 35653

Dear Commissioners:

I hereby request to be reappointed to the NACOLG Board for another year. It has been an honor to represent Franklin County and the Commission.

Thank you in advance.

Sincerely,

A handwritten signature in cursive script that reads "Lavon Duboise".

Lavon Duboise

INDUSTRIAL DEVELOPMENT BOARD

It is on motion of Mr. Chris Wallace second by Mr. Jason Miller, unanimously ordered, adjudged and decreed by the Board to re-appoint Matt Cooper and Timmy James as the District I appointments to the Industrial Development Board with their terms expiring September 30, 2027.

INDUSTRIAL DEVELOPMENT BOARD

It is on motion of Mr. Jason Miller, second by Mr. Chris Wallace, unanimously ordered, adjudged and decreed by the Board to appoint Craig Madden for District II to the Industrial Development Board with his term expiring September 30, 2027.

INDUSTRIAL DEVELOPMENT BOARD

It is on motion of Mr. David Hester, second by Mr. Joseph Baldwin, unanimously ordered, adjudged and decreed by the Board to appoint Phillip Rogers for District IV to the Industrial Development Board with his term expiring September 30, 2027.

INDUSTRIAL DEVELOPMENT BOARD

It is on motion of Mr. Joseph Baldwin, second by Mr. Jason Miller, unanimously ordered, adjudged and decreed by the Board to appoint Mark Holland as Probate Judge Representative to the Industrial Development Board with his term expiring September 30, 2027.

Letter as follows:

17200 Highway 24
Russellville, Alabama 35653
September 11, 2023

Hon. Barry Moore
Franklin County Probate Judge
410 North Jackson Avenue
Russellville, Alabama 35653

Dear Judge Moore:

I am writing to express my interest in being reappointed to the Industrial Development Board. I own and operate a business in Franklin County, and I am a dedicated and motivated to bring in more industry to our county. Franklin County is a great place to live and work.

If you have any questions about this appointment, I can be reached at (256)810-5895 and/or markannakay@bellsouth.net. Please feel free to contact me at your earliest convenience. I look forward to hearing from you.

Sincerely,

Mark Holland

Mark Holland

DEPARTMENT OF HUMAN RESOURCES BOARD

It is on motion of Mr. Chris Wallace, second by Mr. Jason Miller, unanimously ordered, adjudged and decreed by the Board to table the Department of Human Resources Board Appointment until appointees can be found.

ADJOURNMENT

It is on motion of Mr. Chris Wallace, second by Mr. Joseph Baldwin that the meeting be adjourned.



Barry Moore, Chairman



Chris Wallace, District I

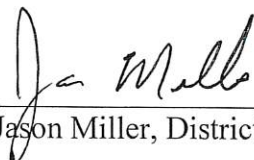

Jason Miller, District II

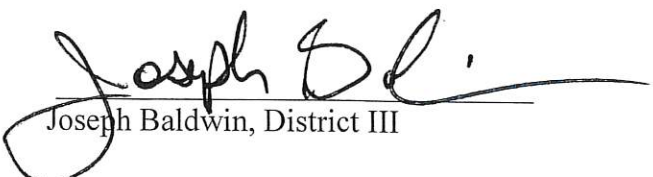

Joseph Baldwin, District III



David Hester, District IV